

Date: **March 23, 2022**

Paul J Ford & Company
250 East Broad Street, STE 600
Columbus, Ohio
614-221-6679

Subject: Structural Analysis Report

Carrier Designation: Verizon Wireless Co-Locate
Site Number: 137514
Site Name: ASHLAND_MA

Crown Castle Designation: BU Number: 806042
Site Name: BOS ASHLAND 959026
JDE Job Number: 693324
Work Order Number: 2094325
Order Number: 593348 Rev. 1

Engineering Firm Designation: Paul J Ford & Company Project Number: 37522-0071.002.7805

Site Data: ALBERT RAY DRIVE FOUNTAIN AND GREEN STREETS,
ASHLAND, Middlesex County, MA
Latitude 42° 16' 25.3", Longitude -71° 27' 5.6"
100 Foot - Monopole Tower

Paul J Ford & Company is pleased to submit this "Structural Analysis Report" to determine the structural integrity of the above-mentioned tower.

The purpose of the analysis is to determine acceptability of the tower stress level. Based on our analysis we have determined the tower stress level for the structure and foundation, under the following load case, to be:

LC7: Proposed Equipment Configuration

Sufficient Capacity

This analysis utilizes an ultimate 3-second gust wind speed of 127 mph as required by the 2015 International Building Code as amended by the Massachusetts State Building Code, Ninth Edition. Applicable Standard references and design criteria are listed in Section 2 - Analysis Criteria.

Respectfully submitted by:



Donna L. Campbell
Structural Designer II
dcampbell@pauljford.com

03/24/2022



TABLE OF CONTENTS

1) INTRODUCTION

2) ANALYSIS CRITERIA

Table 1 - Proposed Equipment Configuration

Table 2 - Other Considered Equipment

3) ANALYSIS PROCEDURE

Table 3 - Documents Provided

3.1) Analysis Method

3.2) Assumptions

4) ANALYSIS RESULTS

Table 4 - Section Capacity (Summary)

Table 5 – Tower Component Stresses vs. Capacity

4.1) Recommendations

5) APPENDIX A

tnxTower Output

6) APPENDIX B

Base Level Drawing

7) APPENDIX C

Additional Calculations

1) INTRODUCTION

This tower is a 100 ft Monopole tower designed by ITT MEYER INC. and mapped by AERO Solutions in February of 2008.

The tower has been modified multiple times to accommodate additional loading.

2) ANALYSIS CRITERIA

TIA-222 Revision:	TIA-222-H
Risk Category:	II
Wind Speed:	127 mph
Exposure Category:	C
Topographic Factor:	1
Ice Thickness:	1.5 in
Wind Speed with Ice:	50 mph
Service Wind Speed:	60 mph

Table 1 - Proposed Equipment Configuration

Mounting Level (ft)	Center Line Elevation (ft)	Number of Antennas	Antenna Manufacturer	Antenna Model	Number of Feed Lines	Feed Line Size (in)
102.0	104.0	2	raycap	RVZDC-6627-PF-48	2 6	1-5/8 7/8
		3	samsung telecommunications	RFV01U-D1A		
		3	samsung telecommunications	RFV01U-D2A		
	102.0	6	commscope	NHH-65B-R2B w/ Mount Pipe		
		3	css	X7C-680 w/ Mount Pipe		
		3	samsung telecommunications	MT6407-77A w/ Mount Pipe		
		1	tower mounts	Platform Mount (LP 101-1)		
		1	tower mounts	Side Arm Mount [SO 203-3]		

Table 2 - Other Considered Equipment

Mounting Level (ft)	Center Line Elevation (ft)	Number of Antennas	Antenna Manufacturer	Antenna Model	Number of Feed Lines	Feed Line Size (in)
94.0	94.0	3	ericsson	ERICSSON AIR 21 B2A B4P	1	1/4
		3	ericsson	ERICSSON AIR 21 B4A B2P	2	1-5/8
		1	tower mounts	T-Arm Mount [TA 702-3]	6	7/8
84.0	87.0	3	cci antennas	DMP65R-BU6e w/ Mount Pipe	7 3 6	7/8 3/8 13/16
		3	ericsson	RRUS 32 B2		
		3	ericsson	RRUS 32 B30		
		3	ericsson	RRUS 32 B66		
		3	ericsson	RRUS 4449 B5/B12		
		3	ericsson	RRUS 4478 B14		
		3	kathrein	80010965 w/ Mount Pipe		
		2	raycap	DC6-48-60-18-8F		

Mounting Level (ft)	Center Line Elevation (ft)	Number of Antennas	Antenna Manufacturer	Antenna Model	Number of Feed Lines	Feed Line Size (in)
	86.0	1	raycap	DC9-48-60-24-8C-EV		
		3	ericsson	AIR 6419 B77G w/ Mount Pipe		
		3	ericsson	AIR 6449 N77 w/ Mount Pipe		
	84.0	2	tower mounts	T-Arm Mount [TA 602-3]		
74.0	74.0	3	fujitsu	TA08025-B604	1	1-3/8
		3	fujitsu	TA08025-B605		
		3	jma wireless	MX08FRO665-21 w/ Mount Pipe		
		1	mounts	Commscope_MC-Pk8-DSH_Platform		
		1	raycap	RDIDC-9181-PF-48		

3) ANALYSIS PROCEDURE

Table 3 - Documents Provided

Document	Reference	Source
4-GEOTECHNICAL REPORTS	1094280	CCISITES
4-TOWER FOUNDATION MAPPING	1094282	CCISITES
4-TOWER MAPPING	2210647	CCISITES
4-TOWER REINFORCEMENT DRAWINGS	1287595	CCISITES
4-POST-MODIFICATION INSPECTION	2033623	CCISITES
4-TOWER REINFORCEMENT DRAWINGS	2217666	CCISITES
4-POST-MODIFICATION INSPECTION	3672212	CCISITES
4-TOWER REINFORCEMENT DRAWINGS	3794055	CCISITES
4-POST-MODIFICATION INSPECTION	3817361	CCISITES

3.1) Analysis Method

tnxTower (version 8.1.1.0), a commercially available analysis software package, was used to create a three-dimensional model of the tower and calculate member stresses for various loading cases. Selected output from the analysis is included in Appendix A. When applicable, Crown Castle has calculated and provided the effective area for panel antennas using approved methods following the intent of the TIA-222 standard.

3.2) Assumptions

- 1) Tower and structures were maintained in accordance with the TIA-222 Standard.
- 2) The configuration of antennas, transmission cables, mounts and other appurtenances are as specified in Tables 1 and 2 and the referenced drawings.
- 3) The structure was modified in conformance with the referenced modification drawings as shown in the referenced post modification inspection.
- 4) The connection at 0'-0" has been analyzed with a finite element analysis, FEA, and found to be sufficient per the referenced CCI Doc ID#10224534. The reactions at this elevation for this analysis comparable to (within 1%) the reactions used in the FEA. Therefore, the flange is assumed to be sufficient for this analysis. See Appendix C for referenced FEA results.

This analysis may be affected if any assumptions are not valid or have been made in error. Paul J Ford & Company should be notified to determine the effect on the structural integrity of the tower.

4) ANALYSIS RESULTS

Table 4 - Section Capacity (Summary)

Elevation (ft)	Component Type	Size	Critical Element	% Capacity	Pass / Fail
100 - 95	Pole	TP15.793x15x0.19	Pole	22.4%	Pass
95 - 90	Pole	TP16.587x15.793x0.19	Pole	37.3%	Pass
90 - 85.5	Pole	TP17.301x16.587x0.19	Pole	49.7%	Pass
85.5 - 85.25	Pole + Reinf.	TP17.34x17.301x0.6025	Reinf. 7 Tension Rupture	24.7%	Pass
85.25 - 80.25	Pole + Reinf.	TP18.134x17.34x0.5775	Reinf. 7 Tension Rupture	37.9%	Pass
80.25 - 75.25	Pole + Reinf.	TP18.927x18.134x0.5525	Reinf. 7 Tension Rupture	49.2%	Pass
75.25 - 70.25	Pole + Reinf.	TP19.72x18.927x0.54	Reinf. 7 Tension Rupture	61.9%	Pass
70.25 - 66.5	Pole + Reinf.	TP20.95x19.72x0.5213	Reinf. 7 Tension Rupture	71.1%	Pass
66.5 - 61.5	Pole + Reinf.	TP20.735x19.94x0.575	Reinf. 7 Tension Rupture	75.9%	Pass
61.5 - 56.5	Pole + Reinf.	TP21.529x20.735x0.5625	Reinf. 7 Tension Rupture	85.5%	Pass
56.5 - 54.75	Pole + Reinf.	TP21.807x21.529x0.5625	Reinf. 7 Tension Rupture	88.7%	Pass
54.75 - 54.5	Pole + Reinf.	TP21.847x21.807x0.7375	Reinf. 3 Tension Rupture	68.4%	Pass
54.5 - 49.5	Pole + Reinf.	TP22.642x21.847x0.7125	Reinf. 3 Tension Rupture	75.5%	Pass
49.5 - 44.5	Pole + Reinf.	TP23.437x22.642x0.6875	Reinf. 3 Tension Rupture	82.1%	Pass
44.5 - 39.5	Pole + Reinf.	TP24.231x23.437x0.675	Reinf. 3 Tension Rupture	88.3%	Pass
39.5 - 34.5	Pole + Reinf.	TP25.026x24.231x0.65	Reinf. 3 Tension Rupture	94.2%	Pass
34.5 - 33	Pole + Reinf.	TP25.9x25.026x0.65	Reinf. 3 Tension Rupture	95.8%	Pass
33 - 28	Pole + Reinf.	TP25.554x24.76x0.925	Reinf. 5 Tension Rupture	76.2%	Pass
28 - 23.5	Pole + Reinf.	TP26.268x25.554x0.9	Reinf. 5 Tension Rupture	80.0%	Pass
23.5 - 23.25	Pole + Reinf.	TP26.308x26.268x0.9	Reinf. 5 Tension Rupture	79.6%	Pass
23.25 - 22.75	Pole + Reinf.	TP26.388x26.308x0.9	Reinf. 5 Tension Rupture	80.0%	Pass
22.75 - 22.5	Pole + Reinf.	TP26.427x26.388x1.05	Reinf. 3 Tension Rupture	73.4%	Pass
22.5 - 17.5	Pole + Reinf.	TP27.221x26.427x1.025	Reinf. 3 Tension Rupture	77.1%	Pass
17.5 - 15.75	Pole + Reinf.	TP27.499x27.221x1	Reinf. 3 Tension Rupture	78.4%	Pass
15.75 - 15.5	Pole + Reinf.	TP27.539x27.499x1.075	Reinf. 6 Tension Rupture	68.5%	Pass

15.5 - 12.25	Pole + Reinf.	TP28.055x27.539x1.0625	Reinf. 6 Tension Rupture	70.6%	Pass
12.25 - 12	Pole + Reinf.	TP28.095x28.055x0.95	Reinf. 1 Tension Rupture	78.6%	Pass
12 - 11.75	Pole + Reinf.	TP28.134x28.095x0.95	Reinf. 1 Tension Rupture	78.8%	Pass
11.75 - 11.5	Pole + Reinf.	TP28.174x28.134x0.75	Reinf. 6 Tension Rupture	91.0%	Pass
11.5 - 6.5	Pole + Reinf.	TP28.968x28.174x0.7375	Reinf. 6 Tension Rupture	94.6%	Pass
6.5 - 6	Pole + Reinf.	TP29.047x28.968x0.7375	Reinf. 6 Tension Rupture	95.0%	Pass
6 - 5.75	Pole + Reinf.	TP29.087x29.047x0.75	Reinf. 10 Tension Rupture	88.0%	Pass
5.75 - 4.5	Pole + Reinf.	TP29.285x29.087x0.75	Reinf. 10 Tension Rupture	88.9%	Pass
4.5 - 4.25	Pole + Reinf.	TP29.325x29.285x0.8	Reinf. 8 Tension Yield	88.9%	Pass
4.25 - 3	Pole + Reinf.	TP29.524x29.325x0.8	Reinf. 8 Tension Yield	89.7%	Pass
3 - 2.75	Pole + Reinf.	TP29.563x29.524x0.8	Reinf. 9 Tension Yield	91.2%	Pass
2.75 - 1.75	Pole + Reinf.	TP29.722x29.563x0.8	Reinf. 9 Tension Yield	91.8%	Pass
1.75 - 1.5	Pole + Reinf.	TP29.762x29.722x0.775	Reinf. 9 Tension Yield	97.2%	Pass
1.5 - 1.25	Pole + Reinf.	TP29.802x29.762x0.775	Reinf. 9 Tension Yield	97.4%	Pass
1.25 - 1	Pole + Reinf.	TP29.841x29.802x0.8	Reinf. 4 Tension Yield	88.3%	Pass
1 - 0	Pole + Reinf.	TP30x29.841x0.8	Reinf. 4 Tension Yield	89.0%	Pass
				Summary	
			Pole	80.7%	Pass
			Reinforcement	97.4%	Pass
			Overall	97.4%	Pass

Table 5 - Tower Component Stresses vs. Capacity

Notes	Component	Elevation (ft)	% Capacity	Pass / Fail
1	Anchor Rods	0	83.5	Pass
1,2	Base Plate	0	Sufficient	
1	Base Foundation (Structure)	0	76.2	Pass
1	Base Foundation (Soil Interaction)	0	78.4	Pass

Structure Rating (max from all components) =	97.4%
---	--------------

Notes:

- All structural ratings are per TIA-222-H Section 15.5
- 1) See additional documentation in "Appendix C – Additional Calculations" for calculations supporting the % capacity consumed.
- 2) The adequacy of the base plate was determined utilizing commercial FEA software

4.1) Recommendations

The tower and its foundation have sufficient capacity to carry the proposed load configuration. No modifications are required at this time.

APPENDIX A
TNXTOWER OUTPUT

Tower Input Data

The tower is a monopole.

This tower is designed using the TIA-222-H standard.

The following design criteria apply:

- 1) Tower base elevation above sea level: 325.0000 ft.
- 2) Basic wind speed of 127 mph.
- 3) Risk Category II.
- 4) Exposure Category C.
- 5) Simplified Topographic Factor Procedure for wind speed-up calculations is used.
- 6) Topographic Category: 1.
- 7) Crest Height: 0.0000 ft.
- 8) Nominal ice thickness of 1.50 in.
- 9) Ice thickness is considered to increase with height.
- 10) Ice density of 56.00 pcf.
- 11) A wind speed of 50 mph is used in combination with ice.
- 12) Temperature drop of 50 °F.
- 13) Deflections calculated using a wind speed of 60 mph.
- 14) TIA-222-H ANNEX S.
- 15) A non-linear (P-delta) analysis was used.
- 16) Pressures are calculated at each section.
- 17) Stress ratio used in pole design is 1.
- 18) Tower analysis based on target reliabilities in accordance with Annex S.
- 19) Load Modification Factors used: $K_{es}(F_w) = 0.95$, $K_{es}(t_i) = 0.85$.
- 20) Maximum demand-capacity ratio is: 1.05.
- 21) Local bending stresses due to climbing loads, feed line supports, and appurtenance mounts are not considered.

Options

Consider Moments - Legs Consider Moments - Horizontals Consider Moments - Diagonals Use Moment Magnification ✓ Use Code Stress Ratios ✓ Use Code Safety Factors - Guys Escalate Ice Always Use Max Kz Use Special Wind Profile Include Bolts In Member Capacity Leg Bolts Are At Top Of Section Secondary Horizontal Braces Leg Use Diamond Inner Bracing (4 Sided) SR Members Have Cut Ends SR Members Are Concentric	Distribute Leg Loads As Uniform Assume Legs Pinned ✓ Assume Rigid Index Plate ✓ Use Clear Spans For Wind Area Use Clear Spans For KL/r Retension Guys To Initial Tension ✓ Bypass Mast Stability Checks ✓ Use Azimuth Dish Coefficients ✓ Project Wind Area of Appurt. Autocalc Torque Arm Areas Add IBC .6D+W Combination Sort Capacity Reports By Component Triangulate Diamond Inner Bracing Treat Feed Line Bundles As Cylinder Ignore KL/ry For 60 Deg. Angle Legs	Use ASCE 10 X-Brace Ly Rules Calculate Redundant Bracing Forces Ignore Redundant Members in FEA SR Leg Bolts Resist Compression All Leg Panels Have Same Allowable Offset Girt At Foundation ✓ Consider Feed Line Torque Include Angle Block Shear Check Use TIA-222-H Bracing Resist. Exemption Use TIA-222-H Tension Splice Exemption <div style="text-align: center; background-color: #e0e0e0; padding: 2px;">Poles</div> ✓ Include Shear-Torsion Interaction Always Use Sub-Critical Flow Use Top Mounted Sockets Pole Without Linear Attachments Pole With Shroud Or No Appurtenances Outside and Inside Corner Radii Are Known
--	---	---

Tapered Pole Section Geometry

Section	Elevation ft	Section Length ft	Splice Length ft	Number of Sides	Top Diameter in	Bottom Diameter in	Wall Thickness in	Bend Radius in	Pole Grade
L1	100.0000-95.0000	5.0000	0.00	12	15.00	15.79	0.19	0.76	A572-65 (65 ksi)
L2	95.0000-90.0000	5.0000	0.00	12	15.79	16.59	0.19	0.76	A572-65 (65 ksi)
L3	90.0000-85.5000	4.5000	0.00	12	16.59	17.30	0.19	0.76	A572-65 (65 ksi)
L4	85.5000-85.2500	0.2500	0.00	12	17.30	17.34	0.60	2.41	A572-65 (65 ksi)
L5	85.2500-80.2500	5.0000	0.00	12	17.34	18.13	0.58	2.31	A572-65 (65 ksi)
L6	80.2500-75.2500	5.0000	0.00	12	18.13	18.93	0.55	2.21	A572-65 (65 ksi)
L7	75.2500-70.2500	5.0000	0.00	12	18.93	19.72	0.54	2.16	A572-65 (65 ksi)
L8	70.2500-62.5000	7.7500	4.00	12	19.72	20.95	0.52	2.09	A572-65 (65 ksi)
L9	62.5000-61.5000	5.0000	0.00	12	19.94	20.73	0.57	2.30	A572-65 (65 ksi)
L10	61.5000-56.5000	5.0000	0.00	12	20.73	21.53	0.56	2.25	A572-65 (65 ksi)
L11	56.5000-54.7500	1.7500	0.00	12	21.53	21.81	0.56	2.25	A572-65 (65 ksi)
L12	54.7500-54.5000	0.2500	0.00	12	21.81	21.85	0.74	2.95	A572-65 (65 ksi)
L13	54.5000-49.5000	5.0000	0.00	12	21.85	22.64	0.71	2.85	A572-65 (65 ksi)
L14	49.5000-44.5000	5.0000	0.00	12	22.64	23.44	0.69	2.75	A572-65 (65 ksi)
L15	44.5000-39.5000	5.0000	0.00	12	23.44	24.23	0.68	2.70	A572-65 (65 ksi)
L16	39.5000-34.5000	5.0000	0.00	12	24.23	25.03	0.65	2.60	A572-65 (65 ksi)
L17	34.5000-29.0000	5.5000	4.00	12	25.03	25.90	0.65	2.60	A572-65 (65 ksi)
L18	29.0000-28.0000	5.0000	0.00	12	24.76	25.55	0.93	3.70	A572-65 (65 ksi)
L19	28.0000-23.5000	4.5000	0.00	12	25.55	26.27	0.90	3.60	A572-65 (65 ksi)
L20	23.5000-23.2500	0.2500	0.00	12	26.27	26.31	0.90	3.60	A572-65 (65 ksi)
L21	23.2500-22.7500	0.5000	0.00	12	26.31	26.39	0.90	3.60	A572-65 (65 ksi)
L22	22.7500-22.5000	0.2500	0.00	12	26.39	26.43	1.05	4.20	A572-65 (65 ksi)
L23	22.5000-17.5000	5.0000	0.00	12	26.43	27.22	1.02	4.10	A572-65 (65 ksi)
L24	17.5000-15.7500	1.7500	0.00	12	27.22	27.50	1.00	4.00	A572-65 (65 ksi)
L25	15.7500-15.5000	0.2500	0.00	12	27.50	27.54	1.08	4.30	A572-65 (65 ksi)
L26	15.5000-12.2500	3.2500	0.00	12	27.54	28.05	1.06	4.25	A572-65 (65 ksi)
L27	12.2500-12.0000	0.2500	0.00	12	28.05	28.09	0.95	3.80	A572-65 (65 ksi)
L28	12.0000-11.7500	0.2500	0.00	12	28.09	28.13	0.95	3.80	A572-65 (65 ksi)
L29	11.7500-11.5000	0.2500	0.00	12	28.13	28.17	0.75	3.00	A572-65 (65 ksi)
L30	11.5000-6.5000	5.0000	0.00	12	28.17	28.97	0.74	2.95	A572-65 (65 ksi)
L31	6.5000-6.0000	0.5000	0.00	12	28.97	29.05	0.74	2.95	A572-65 (65 ksi)
L32	6.0000-5.7500	0.2500	0.00	12	29.05	29.09	0.75	3.00	A572-65 (65 ksi)
L33	5.7500-4.5000	1.2500	0.00	12	29.09	29.29	0.75	3.00	A572-65 (65 ksi)
L34	4.5000-4.2500	0.2500	0.00	12	29.29	29.33	0.80	3.20	A572-65 (65 ksi)
L35	4.2500-3.0000	1.2500	0.00	12	29.33	29.52	0.80	3.20	A572-65

Section	Elevation ft	Section Length ft	Splice Length ft	Number of Sides	Top Diameter in	Bottom Diameter in	Wall Thickness in	Bend Radius in	Pole Grade
L36	3.0000-2.7500	0.2500	0.00	12	29.52	29.56	0.80	3.20	(65 ksi) A572-65
L37	2.7500-1.7500	1.0000	0.00	12	29.56	29.72	0.80	3.20	(65 ksi) A572-65
L38	1.7500-1.5000	0.2500	0.00	12	29.72	29.76	0.78	3.10	(65 ksi) A572-65
L39	1.5000-1.2500	0.2500	0.00	12	29.76	29.80	0.78	3.10	(65 ksi) A572-65
L40	1.2500-1.0000	0.2500	0.00	12	29.80	29.84	0.80	3.20	(65 ksi) A572-65
L41	1.0000-0.0000	1.0000		12	29.84	30.00	0.80	3.20	(65 ksi) A572-65

Tapered Pole Properties

Section	Tip Dia. in	Area in ²	I in ⁴	r in	C in	I/C in ³	J in ⁴	It/Q in ²	w in	w/t
L1	15.46	9.06	253.67	5.30	7.77	32.65	513.99	4.46	3.51	18.478
	16.28	9.55	296.65	5.59	8.18	36.26	601.10	4.70	3.72	19.597
L2	16.28	9.55	296.65	5.59	8.18	36.26	601.10	4.70	3.72	19.597
	17.10	10.03	344.24	5.87	8.59	40.07	697.52	4.94	3.94	20.716
L3	17.10	10.03	344.24	5.87	8.59	40.07	697.52	4.94	3.94	20.716
	17.84	10.47	391.20	6.13	8.96	43.65	792.67	5.15	4.13	21.723
L4	17.70	32.40	1152.94	5.98	8.96	128.65	2336.16	15.94	3.02	5.016
	17.74	32.47	1161.17	5.99	8.98	129.27	2352.85	15.98	3.03	5.033
L5	17.75	31.17	1117.99	6.00	8.98	124.47	2265.34	15.34	3.10	5.367
	18.57	32.65	1284.35	6.29	9.39	136.73	2602.44	16.07	3.31	5.735
L6	18.58	31.28	1234.01	6.29	9.39	131.37	2500.43	15.39	3.38	6.116
	19.40	32.69	1408.71	6.58	9.80	143.68	2854.42	16.09	3.59	6.501
L7	19.40	31.97	1379.65	6.58	9.80	140.72	2795.54	15.74	3.63	6.713
	20.23	33.35	1566.04	6.87	10.22	153.31	3173.23	16.41	3.84	7.107
L8	20.23	32.22	1516.11	6.87	10.22	148.42	3072.04	15.86	3.89	7.459
	21.51	34.29	1826.47	7.31	10.85	168.31	3700.93	16.88	4.22	8.091
L9	21.10	35.85	1716.18	6.93	10.33	166.15	3477.44	17.65	3.80	6.614
	21.26	37.33	1936.24	7.22	10.74	180.27	3923.35	18.37	4.02	6.984
L10	21.27	36.54	1897.68	7.22	10.74	176.68	3845.21	17.98	4.05	7.199
	22.09	37.98	2130.90	7.51	11.15	191.07	4317.78	18.69	4.26	7.578
L11	22.09	37.98	2130.90	7.51	11.15	191.07	4317.78	18.69	4.26	7.578
	22.38	38.48	2216.83	7.61	11.30	196.24	4491.90	18.94	4.34	7.71
L12	22.32	50.04	2835.28	7.54	11.30	250.99	5745.04	24.63	3.87	5.245
	22.36	50.13	2851.35	7.56	11.32	251.96	5777.60	24.67	3.88	5.259
L13	22.37	48.49	2764.49	7.57	11.32	244.28	5601.61	23.86	3.95	5.538
	23.19	50.31	3088.20	7.85	11.73	263.31	6257.52	24.76	4.16	5.837
L14	23.20	48.60	2990.04	7.86	11.73	254.94	6058.64	23.92	4.23	6.146
	24.02	50.36	3326.62	8.14	12.14	274.02	6740.64	24.79	4.44	6.456
L15	24.03	49.47	3271.52	8.15	12.14	269.48	6628.99	24.35	4.47	6.625
	24.85	51.20	3626.28	8.43	12.55	288.91	7347.83	25.20	4.68	6.941
L16	24.86	49.36	3503.10	8.44	12.55	279.09	7098.24	24.29	4.75	7.311
	25.68	51.02	3869.33	8.73	12.96	298.48	7840.30	25.11	4.96	7.638
L17	25.68	51.02	3869.33	8.73	12.96	298.48	7840.30	25.11	4.96	7.638
	26.58	52.85	4300.70	9.04	13.42	320.56	8714.39	26.01	5.20	7.999
L18	25.96	70.99	5147.89	8.53	12.83	401.37	10431.02	34.94	4.16	4.494
	26.13	73.36	5679.64	8.82	13.24	429.07	11508.49	36.10	4.37	4.724
L19	26.14	71.45	5542.98	8.83	13.24	418.75	11231.58	35.16	4.44	4.929
	26.88	73.52	6039.04	9.08	13.61	443.82	12236.73	36.18	4.63	5.142
L20	26.88	73.52	6039.04	9.08	13.61	443.82	12236.73	36.18	4.63	5.142
	26.92	73.63	6067.43	9.10	13.63	445.23	12294.27	36.24	4.64	5.154
L21	26.92	73.63	6067.43	9.10	13.63	445.23	12294.27	36.24	4.64	5.154
	27.00	73.86	6124.49	9.12	13.67	448.06	12409.88	36.35	4.66	5.178
L22	26.95	85.67	7019.83	9.07	13.67	513.57	14224.07	42.16	4.26	4.055
	26.99	85.80	7052.87	9.09	13.69	515.21	14291.03	42.23	4.27	4.065
L23	27.00	83.84	6905.31	9.09	13.69	504.43	13992.04	41.26	4.34	4.23
	27.82	86.46	7573.23	9.38	14.10	537.09	15345.42	42.55	4.55	4.437
L24	27.83	84.43	7409.69	9.39	14.10	525.49	15014.04	41.56	4.62	4.615

100 Ft Monopole Tower Structural Analysis
 Project Number 37522-0071.002.7805, Order 593348, Revision 1

Section	Tip Dia. in	Area in ²	I in ⁴	r in	C in	I/C in ³	J in ⁴	It/Q in ²	w in	w/t
	28.12	85.33	7647.77	9.49	14.24	536.89	15496.45	42.00	4.69	4.69
L25	28.09	91.47	8151.74	9.46	14.24	572.27	16517.64	45.02	4.49	4.176
	28.13	91.60	8188.54	9.47	14.27	574.03	16592.20	45.08	4.50	4.185
L26	28.14	90.58	8104.80	9.48	14.27	568.16	16422.51	44.58	4.53	4.266
	28.67	92.35	8588.01	9.66	14.53	590.96	17401.65	45.45	4.67	4.396
L27	28.71	82.91	7775.11	9.70	14.53	535.02	15754.47	40.81	4.97	5.234
	28.75	83.04	7809.32	9.72	14.55	536.61	15823.80	40.87	4.98	5.246
L28	28.75	83.04	7809.32	9.72	14.55	536.61	15823.80	40.87	4.98	5.246
	28.79	83.16	7843.63	9.73	14.57	538.21	15893.32	40.93	4.99	5.257
L29	28.86	66.13	6330.02	9.80	14.57	434.35	12826.34	32.55	5.53	7.373
	28.90	66.23	6357.59	9.82	14.59	435.63	12882.20	32.60	5.54	7.387
L30	28.91	65.15	6260.18	9.82	14.59	428.95	12684.83	32.07	5.57	7.558
	29.73	67.04	6819.52	10.11	15.01	454.47	13818.20	33.00	5.79	7.847
L31	29.73	67.04	6819.52	10.11	15.01	454.47	13818.20	33.00	5.79	7.847
	29.81	67.23	6877.22	10.13	15.05	457.06	13935.12	33.09	5.81	7.875
L32	29.81	68.34	6984.52	10.13	15.05	464.20	14152.54	33.63	5.77	7.7
	29.85	68.43	7013.96	10.14	15.07	465.52	14212.19	33.68	5.79	7.714
L33	29.85	68.43	7013.96	10.14	15.07	465.52	14212.19	33.68	5.79	7.714
	30.05	68.91	7162.38	10.22	15.17	472.15	14512.93	33.92	5.84	7.785
L34	30.04	73.38	7599.78	10.20	15.17	500.98	15399.22	36.11	5.70	7.131
	30.08	73.48	7631.60	10.21	15.19	502.40	15463.69	36.17	5.72	7.144
L35	30.08	73.48	7631.60	10.21	15.19	502.40	15463.69	36.17	5.72	7.144
	30.28	73.99	7792.02	10.28	15.29	509.51	15788.74	36.42	5.77	7.21
L36	30.28	73.99	7792.02	10.28	15.29	509.51	15788.74	36.42	5.77	7.21
	30.32	74.09	7824.37	10.30	15.31	510.94	15854.30	36.47	5.78	7.224
L37	30.32	74.09	7824.37	10.30	15.31	510.94	15854.30	36.47	5.78	7.224
	30.49	74.50	7954.67	10.35	15.40	516.67	16118.32	36.67	5.82	7.277
L38	30.50	72.24	7726.09	10.36	15.40	501.82	15655.15	35.55	5.89	7.598
	30.54	72.34	7757.92	10.38	15.42	503.22	15719.64	35.60	5.90	7.612
L39	30.54	72.34	7757.92	10.38	15.42	503.22	15719.64	35.60	5.90	7.612
	30.58	72.44	7789.83	10.39	15.44	504.61	15784.32	35.65	5.91	7.626
L40	30.57	74.71	8020.36	10.38	15.44	519.55	16251.42	36.77	5.84	7.304
	30.61	74.81	8053.34	10.40	15.46	520.99	16318.25	36.82	5.85	7.317
L41	30.61	74.81	8053.34	10.40	15.46	520.99	16318.25	36.82	5.85	7.317
	30.78	75.22	8186.16	10.45	15.54	526.78	16587.38	37.02	5.90	7.37

Tower Elevation	Gusset Area (per face)	Gusset Thickness	Gusset Grade	Adjust. Factor A _r	Adjust. Factor A _r	Weight Mult.	Double Angle Stitch Bolt Spacing Diagonals	Double Angle Stitch Bolt Spacing Horizontal	Double Angle Stitch Bolt Spacing Redundants
ft	ft ²	in					in	in	in
L1 100.0000-95.0000				1	1	1			
L2 95.0000-90.0000				1	1	1			
L3 90.0000-85.5000				1	1	1			
L4 85.5000-85.2500				1	1	0.845857			
L5 85.2500-80.2500				1	1	0.856207			
L6 80.2500-75.2500				1	1	0.86994			
L7 75.2500-70.2500				1	1	0.867235			
L8 70.2500-62.5000				1	1	0.88153			
L9 62.5000-61.5000				1	1	0.896555			
L10 61.5000-56.5000				1	1	0.898041			
L11 56.5000-54.7500				1	1	0.892103			
L12 54.7500-54.5000				1	1	0.854418			
L13 54.5000-49.5000				1	1	0.864055			
L14 49.5000-44.5000				1	1	0.875913			

Tower Elevation	Gusset Area (per face)	Gusset Thickness	Gusset Grade	Adjust. Factor A_r	Adjust. Factor A_r	Weight Mult.	Double Angle Stitch Bolt Spacing Diagonals in	Double Angle Stitch Bolt Spacing Horizontals in	Double Angle Stitch Bolt Spacing Redundants in
ft	ft ²	in							
L15 44.5000-39.5000				1	1	0.874059			
L16 39.5000-34.5000				1	1	0.889694			
L17 34.5000-29.0000				1	1	0.884802			
L18 29.0000-28.0000				1	1	0.855953			
L19 28.0000-23.5000				1	1	0.861908			
L20 23.5000-23.2500				1	1	1.0242			
L21 23.2500-22.7500				1	1	1.02187			
L22 22.7500-22.5000				1	1	0.974904			
L23 22.5000-17.5000				1	1	0.974853			
L24 17.5000-15.7500				1	1	0.990425			
L25 15.7500-15.5000				1	1	1.0155			
L26 15.5000-12.2500				1	1	1.01183			
L27 12.2500-12.0000				1	1	1.05755			
L28 12.0000-11.7500				1	1	1.05639			
L29 11.7500-11.5000				1	1	1.1988			
L30 11.5000-6.5000				1	1	1.19383			
L31 6.5000-6.0000				1	1	1.19143			
L32 6.0000-5.7500				1	1	1.26512			
L33 5.7500-4.5000				1	1	1.25864			
L34 4.5000-4.2500				1	1	1.18015			
L35 4.2500-3.0000				1	1	1.17416			
L36 3.0000-2.7500				1	1	1.13918			
L37 2.7500-1.7500				1	1	1.13464			
L38 1.7500-1.5000				1	1	1.05524			
L39 1.5000-1.2500				1	1	1.05424			
L40 1.2500-1.0000				1	1	0.954982			
L41 1.0000-0.0000				1	1	0.951488			

Feed Line/Linear Appurtenances - Entered As Round Or Flat

Description	Sector	Exclude From Torque Calculation	Component Type	Placement ft	Total Number	Number Per Row	Start/End Position	Width or Diameter in	Perimeter r in	Weight plf
-------------	--------	---------------------------------	----------------	--------------	--------------	----------------	--------------------	----------------------	----------------	------------

Description	Sector	Exclude From Torque Calculation	Component Type	Placement ft	Total Number	Number Per Row	Start/End Position	Width or Diameter in	Perimeter in	Weight plf
MLE HYBRID 9POWER/18FIBER RL 2(1-5/8)	B	No	Surface Ar (CaAa)	94.0000 - 0.0000	2	2	-0.420 -0.400	1.63		1.07
FXL 780 PE(7/8)	B	No	Surface Ar (CaAa)	94.0000 - 0.0000	4	4	-0.380 -0.350	1.09		0.25
FXL 780 PE(7/8)	B	No	Surface Ar (CaAa)	94.0000 - 0.0000	2	2	-0.320 -0.300	1.09		0.25
LDF1-50A(1/4)	B	No	Surface Ar (CaAa)	94.0000 - 0.0000	1	1	-0.330 -0.330	0.34		0.06

CR 50 1070(7/8)	B	No	Surface Ar (CaAa)	84.0000 - 0.0000	6	6	0.450 0.470	0.00		0.28
FB-L98B-034-XXX(3/8)	C	No	Surface Ar (CaAa)	84.0000 - 0.0000	2	1	-0.400 -0.390	0.00		0.06

CU12PSM9P8XXX(1-3/8)	A	No	Surface Ar (CaAa)	74.0000 - 0.0000	1	1	-0.009 0.009	1.41		1.66

MP3-06	B	No	Surface Af (CaAa)	58.0000 - 1.7500	1	1	-0.226 -0.226	6.89	19.00	0.00
MP3-06	A	No	Surface Af (CaAa)	58.0000 - 1.7500	1	1	-0.226 -0.226	6.89	19.00	0.00
MP3-06	C	No	Surface Af (CaAa)	19.0000 - 1.7500	1	1	0.024 0.024	6.89	19.00	0.00
MP3-06	C	No	Surface Af (CaAa)	58.0000 - 8.5000	1	1	-0.226 -0.226	6.89	19.00	0.00
MP3-05	A	No	Surface Af (CaAa)	35.0000 - 10.0000	1	1	0.274 0.274	5.33	14.84	0.00
MP3-05	C	No	Surface Af (CaAa)	32.0000 - 2.2500	1	1	0.274 0.274	5.33	14.84	0.00
MP3-05	B	No	Surface Af (CaAa)	32.0000 - 2.2500	1	1	0.274 0.274	5.33	14.84	0.00
MP3-05	B	No	Surface Af (CaAa)	88.0000 - 58.0000	1	1	-0.226 -0.226	5.33	14.84	0.00
MP3-05	A	No	Surface Af (CaAa)	88.0000 - 58.0000	1	1	-0.226 -0.226	5.33	14.84	0.00
MP3-05	C	No	Surface Af (CaAa)	88.0000 - 58.0000	1	1	-0.226 -0.226	5.33	14.84	0.00
CCI-065125	B	No	Surface Af (CaAa)	25.5000 - 0.5000	1	1	-0.476 -0.476	6.50	15.50	0.00
CCI-060100	A	No	Surface Af (CaAa)	25.5000 - 4.0000	1	1	-0.476 -0.476	6.00	14.00	0.00
CCI-060100	B	No	Surface Af (CaAa)	25.5000 - 4.0000	1	1	0.024 0.024	6.00	14.00	0.00

Stacked Plate	B	No	Surface Af (CaAa)	71.5000 - 1.5000	1	1	-0.476 -0.476	6.00	17.00	0.00
Stacked Plate	A	No	Surface Af (CaAa)	71.5000 - 1.5000	1	1	-0.476 -0.476	6.00	17.00	0.00
Stacked Plate	B	No	Surface Af (CaAa)	71.5000 - 1.5000	1	1	0.274 0.274	6.00	17.00	0.00
5 x 1.25	B	No	Surface Af (CaAa)	81.5000 - 71.5000	1	1	-0.476 -0.476	5.00	12.50	0.00
5 x 1.25	A	No	Surface Af (CaAa)	81.5000 - 71.5000	1	1	-0.476 -0.476	5.00	12.50	0.00
5 x 1.25	B	No	Surface Af (CaAa)	81.5000 - 71.5000	1	1	0.274 0.274	5.00	12.50	0.00

Feed Line/Linear Appurtenances - Entered As Area

Description	Face or Leg	Allow Shield	Exclude From Torque Calculation	Component Type	Placement ft	Total Number		C _{AA} ft ² /ft	Weight plf
LDF5-50A(7/8)	C	No	No	Inside Pole	100.0000 - 0.0000	6	No Ice	0.0000	0.33
							1/2" Ice	0.0000	0.33
							1" Ice	0.0000	0.33
							2" Ice	0.0000	0.33
HB158-1-08U8-S8J18(1-5/8)	C	No	No	Inside Pole	100.0000 - 0.0000	1	No Ice	0.0000	1.30
							1/2" Ice	0.0000	1.30
							1" Ice	0.0000	1.30
							2" Ice	0.0000	1.30
HB158-1-08U8-S8J18(1-5/8)	C	No	No	Inside Pole	100.0000 - 0.0000	1	No Ice	0.0000	1.30
							1/2" Ice	0.0000	1.30
							1" Ice	0.0000	1.30
							2" Ice	0.0000	1.30
FB-L98B-235-XXX(3/8)	C	No	No	Inside Pole	84.0000 - 0.0000	1	No Ice	0.0000	0.06
							1/2" Ice	0.0000	0.06
							1" Ice	0.0000	0.06
							2" Ice	0.0000	0.06
PWRT-606-S(7/8)	C	No	No	Inside Pole	84.0000 - 0.0000	1	No Ice	0.0000	0.89
							1/2" Ice	0.0000	0.89
							1" Ice	0.0000	0.89
							2" Ice	0.0000	0.89
PWRT-608-S(13/16)	C	No	No	Inside Pole	84.0000 - 0.0000	6	No Ice	0.0000	0.62
							1/2" Ice	0.0000	0.62
							1" Ice	0.0000	0.62
							2" Ice	0.0000	0.62

Feed Line/Linear Appurtenances Section Areas

Tower Section n	Tower Elevation ft	Face	A _R ft ²	A _F ft ²	C _{AA} In Face ft ²	C _{AA} Out Face ft ²	Weight K
L1	100.0000-95.0000	A	0.000	0.000	0.000	0.000	0.00
		B	0.000	0.000	0.000	0.000	0.00
		C	0.000	0.000	0.000	0.000	0.02
L2	95.0000-90.0000	A	0.000	0.000	0.000	0.000	0.00
		B	0.000	0.000	4.054	0.000	0.01
		C	0.000	0.000	0.000	0.000	0.02
L3	90.0000-85.5000	A	0.000	0.000	2.221	0.000	0.00
		B	0.000	0.000	6.782	0.000	0.02
		C	0.000	0.000	2.221	0.000	0.02
L4	85.5000-85.2500	A	0.000	0.000	0.222	0.000	0.00
		B	0.000	0.000	0.475	0.000	0.00
		C	0.000	0.000	0.222	0.000	0.00
L5	85.2500-80.2500	A	0.000	0.000	5.454	0.000	0.00
		B	0.000	0.000	11.533	0.000	0.02
		C	0.000	0.000	4.442	0.000	0.04
L6	80.2500-75.2500	A	0.000	0.000	8.489	0.000	0.00
		B	0.000	0.000	17.604	0.000	0.03
		C	0.000	0.000	4.442	0.000	0.05
L7	75.2500-70.2500	A	0.000	0.000	9.256	0.000	0.01
		B	0.000	0.000	18.080	0.000	0.03
		C	0.000	0.000	4.442	0.000	0.05
L8	70.2500-62.5000	A	0.000	0.000	15.728	0.000	0.01
		B	0.000	0.000	30.239	0.000	0.04
		C	0.000	0.000	6.885	0.000	0.07
L9	62.5000-61.5000	A	0.000	0.000	2.029	0.000	0.00
		B	0.000	0.000	3.902	0.000	0.01
		C	0.000	0.000	0.888	0.000	0.01
L10	61.5000-56.5000	A	0.000	0.000	10.537	0.000	0.01
		B	0.000	0.000	19.899	0.000	0.03
		C	0.000	0.000	4.832	0.000	0.05
L11	56.5000-54.7500	A	0.000	0.000	4.007	0.000	0.00
		B	0.000	0.000	7.283	0.000	0.01

Tower Section	Tower Elevation	Face	A _R	A _F	C _A A _A In Face	C _A A _A Out Face	Weight
n	ft		ft ²	ft ²	ft ²	ft ²	K
L12	54.7500-54.5000	C	0.000	0.000	2.010	0.000	0.02
		A	0.000	0.000	0.572	0.000	0.00
		B	0.000	0.000	1.040	0.000	0.00
L13	54.5000-49.5000	C	0.000	0.000	0.287	0.000	0.00
		A	0.000	0.000	11.447	0.000	0.01
		B	0.000	0.000	20.809	0.000	0.03
L14	49.5000-44.5000	C	0.000	0.000	5.742	0.000	0.05
		A	0.000	0.000	11.447	0.000	0.01
		B	0.000	0.000	20.809	0.000	0.03
L15	44.5000-39.5000	C	0.000	0.000	5.742	0.000	0.05
		A	0.000	0.000	11.447	0.000	0.01
		B	0.000	0.000	20.809	0.000	0.03
L16	39.5000-34.5000	C	0.000	0.000	5.742	0.000	0.05
		A	0.000	0.000	11.891	0.000	0.01
		B	0.000	0.000	20.809	0.000	0.03
L17	34.5000-29.0000	C	0.000	0.000	5.742	0.000	0.05
		A	0.000	0.000	17.478	0.000	0.01
		B	0.000	0.000	25.555	0.000	0.03
L18	29.0000-28.0000	C	0.000	0.000	8.981	0.000	0.05
		A	0.000	0.000	3.178	0.000	0.00
		B	0.000	0.000	5.050	0.000	0.01
L19	28.0000-23.5000	C	0.000	0.000	2.037	0.000	0.01
		A	0.000	0.000	16.300	0.000	0.01
		B	0.000	0.000	26.892	0.000	0.02
L20	23.5000-23.2500	C	0.000	0.000	9.165	0.000	0.04
		A	0.000	0.000	1.044	0.000	0.00
		B	0.000	0.000	1.783	0.000	0.00
L21	23.2500-22.7500	C	0.000	0.000	0.509	0.000	0.00
		A	0.000	0.000	2.089	0.000	0.00
		B	0.000	0.000	3.567	0.000	0.00
L22	22.7500-22.5000	C	0.000	0.000	1.018	0.000	0.00
		A	0.000	0.000	1.044	0.000	0.00
		B	0.000	0.000	1.783	0.000	0.00
L23	22.5000-17.5000	C	0.000	0.000	0.509	0.000	0.00
		A	0.000	0.000	20.889	0.000	0.01
		B	0.000	0.000	35.667	0.000	0.03
L24	17.5000-15.7500	C	0.000	0.000	11.906	0.000	0.05
		A	0.000	0.000	7.311	0.000	0.00
		B	0.000	0.000	12.484	0.000	0.01
L25	15.7500-15.5000	C	0.000	0.000	5.574	0.000	0.02
		A	0.000	0.000	1.044	0.000	0.00
		B	0.000	0.000	1.783	0.000	0.00
L26	15.5000-12.2500	C	0.000	0.000	0.796	0.000	0.00
		A	0.000	0.000	13.578	0.000	0.01
		B	0.000	0.000	23.184	0.000	0.02
L27	12.2500-12.0000	C	0.000	0.000	10.351	0.000	0.03
		A	0.000	0.000	1.044	0.000	0.00
		B	0.000	0.000	1.783	0.000	0.00
L28	12.0000-11.7500	C	0.000	0.000	0.796	0.000	0.00
		A	0.000	0.000	1.044	0.000	0.00
		B	0.000	0.000	1.783	0.000	0.00
L29	11.7500-11.5000	C	0.000	0.000	0.796	0.000	0.00
		A	0.000	0.000	1.044	0.000	0.00
		B	0.000	0.000	1.783	0.000	0.00
L30	11.5000-6.5000	C	0.000	0.000	0.796	0.000	0.00
		A	0.000	0.000	17.780	0.000	0.01
		B	0.000	0.000	35.667	0.000	0.03
L31	6.5000-6.0000	C	0.000	0.000	13.628	0.000	0.05
		A	0.000	0.000	1.645	0.000	0.00
		B	0.000	0.000	3.567	0.000	0.00
L32	6.0000-5.7500	C	0.000	0.000	1.018	0.000	0.00
		A	0.000	0.000	0.822	0.000	0.00
		B	0.000	0.000	1.783	0.000	0.00
L33	5.7500-4.5000	C	0.000	0.000	0.509	0.000	0.00
		A	0.000	0.000	4.112	0.000	0.00
		B	0.000	0.000	8.917	0.000	0.01
L34	4.5000-4.2500	C	0.000	0.000	2.546	0.000	0.01
		A	0.000	0.000	0.822	0.000	0.00
		B	0.000	0.000	1.783	0.000	0.00

Tower Section n	Tower Elevation ft	Face	A _R ft ²	A _F ft ²	C _A A _A In Face ft ²	C _A A _A Out Face ft ²	Weight K
L35	4.2500-3.0000	C	0.000	0.000	0.509	0.000	0.00
		A	0.000	0.000	3.112	0.000	0.00
		B	0.000	0.000	7.917	0.000	0.01
L36	3.0000-2.7500	C	0.000	0.000	2.546	0.000	0.01
		A	0.000	0.000	0.572	0.000	0.00
		B	0.000	0.000	1.533	0.000	0.00
L37	2.7500-1.7500	C	0.000	0.000	0.509	0.000	0.00
		A	0.000	0.000	2.289	0.000	0.00
		B	0.000	0.000	5.689	0.000	0.01
L38	1.7500-1.5000	C	0.000	0.000	1.593	0.000	0.01
		A	0.000	0.000	0.285	0.000	0.00
		B	0.000	0.000	1.024	0.000	0.00
L39	1.5000-1.2500	C	0.000	0.000	0.000	0.000	0.00
		A	0.000	0.000	0.035	0.000	0.00
		B	0.000	0.000	0.524	0.000	0.00
L40	1.2500-1.0000	C	0.000	0.000	0.000	0.000	0.00
		A	0.000	0.000	0.035	0.000	0.00
		B	0.000	0.000	0.524	0.000	0.00
L41	1.0000-0.0000	C	0.000	0.000	0.000	0.000	0.00
		A	0.000	0.000	0.141	0.000	0.00
		B	0.000	0.000	1.555	0.000	0.01
		C	0.000	0.000	0.000	0.000	0.01

Feed Line/Linear Appurtenances Section Areas - With Ice

Tower Section n	Tower Elevation ft	Face or Leg	Ice Thickness in	A _R ft ²	A _F ft ²	C _A A _A In Face ft ²	C _A A _A Out Face ft ²	Weight K
L1	100.0000-95.0000	A	1.421	0.000	0.000	0.000	0.000	0.00
		B		0.000	0.000	0.000	0.000	0.00
		C		0.000	0.000	0.000	0.000	0.02
L2	95.0000-90.0000	A	1.413	0.000	0.000	0.000	0.000	0.00
		B		0.000	0.000	10.404	0.000	0.11
		C		0.000	0.000	0.000	0.000	0.02
L3	90.0000-85.5000	A	1.406	0.000	0.000	2.924	0.000	0.03
		B		0.000	0.000	14.596	0.000	0.15
		C		0.000	0.000	2.924	0.000	0.05
L4	85.5000-85.2500	A	1.402	0.000	0.000	0.292	0.000	0.00
		B		0.000	0.000	0.940	0.000	0.01
		C		0.000	0.000	0.292	0.000	0.00
L5	85.2500-80.2500	A	1.398	0.000	0.000	7.036	0.000	0.07
		B		0.000	0.000	22.474	0.000	0.23
		C		0.000	0.000	6.888	0.000	0.11
L6	80.2500-75.2500	A	1.389	0.000	0.000	10.613	0.000	0.10
		B		0.000	0.000	30.021	0.000	0.31
		C		0.000	0.000	7.220	0.000	0.12
L7	75.2500-70.2500	A	1.380	0.000	0.000	12.564	0.000	0.13
		B		0.000	0.000	30.748	0.000	0.31
		C		0.000	0.000	7.201	0.000	0.12
L8	70.2500-62.5000	A	1.367	0.000	0.000	22.086	0.000	0.22
		B		0.000	0.000	51.209	0.000	0.50
		C		0.000	0.000	11.123	0.000	0.19
L9	62.5000-61.5000	A	1.358	0.000	0.000	2.850	0.000	0.03
		B		0.000	0.000	6.608	0.000	0.06
		C		0.000	0.000	1.435	0.000	0.02
L10	61.5000-56.5000	A	1.351	0.000	0.000	14.591	0.000	0.14
		B		0.000	0.000	33.284	0.000	0.32
		C		0.000	0.000	7.534	0.000	0.12
L11	56.5000-54.7500	A	1.343	0.000	0.000	5.417	0.000	0.05
		B		0.000	0.000	11.943	0.000	0.12
		C		0.000	0.000	2.950	0.000	0.05
L12	54.7500-54.5000	A	1.341	0.000	0.000	0.773	0.000	0.01
		B		0.000	0.000	1.705	0.000	0.02
		C		0.000	0.000	0.421	0.000	0.01
L13	54.5000-49.5000	A	1.334	0.000	0.000	15.450	0.000	0.15
		B		0.000	0.000	34.041	0.000	0.33

Tower Section	Tower Elevation ft	Face or Leg	Ice Thickness in	A _R ft ²	A _F ft ²	C _A A _A In Face ft ²	C _A A _A Out Face ft ²	Weight K
L14	49.5000-44.5000	C		0.000	0.000	8.410	0.000	0.13
		A	1.321	0.000	0.000	15.410	0.000	0.15
		B		0.000	0.000	33.921	0.000	0.32
L15	44.5000-39.5000	C		0.000	0.000	8.383	0.000	0.13
		A	1.306	0.000	0.000	15.365	0.000	0.15
		B		0.000	0.000	33.788	0.000	0.32
L16	39.5000-34.5000	C		0.000	0.000	8.354	0.000	0.13
		A	1.290	0.000	0.000	15.889	0.000	0.15
		B		0.000	0.000	33.640	0.000	0.31
L17	34.5000-29.0000	C		0.000	0.000	8.321	0.000	0.13
		A	1.270	0.000	0.000	23.066	0.000	0.21
		B		0.000	0.000	40.236	0.000	0.37
L18	29.0000-28.0000	C		0.000	0.000	12.537	0.000	0.17
		A	1.256	0.000	0.000	4.194	0.000	0.04
		B		0.000	0.000	7.835	0.000	0.07
L19	28.0000-23.5000	C		0.000	0.000	2.799	0.000	0.03
		A	1.244	0.000	0.000	21.275	0.000	0.19
		B		0.000	0.000	40.182	0.000	0.35
L20	23.5000-23.2500	C		0.000	0.000	12.523	0.000	0.15
		A	1.232	0.000	0.000	1.352	0.000	0.01
		B		0.000	0.000	2.584	0.000	0.02
L21	23.2500-22.7500	C		0.000	0.000	0.694	0.000	0.01
		A	1.230	0.000	0.000	2.704	0.000	0.02
		B		0.000	0.000	5.165	0.000	0.04
L22	22.7500-22.5000	C		0.000	0.000	1.387	0.000	0.02
		A	1.228	0.000	0.000	1.351	0.000	0.01
		B		0.000	0.000	2.581	0.000	0.02
L23	22.5000-17.5000	C		0.000	0.000	0.693	0.000	0.01
		A	1.213	0.000	0.000	26.952	0.000	0.22
		B		0.000	0.000	51.443	0.000	0.43
L24	17.5000-15.7500	C		0.000	0.000	15.832	0.000	0.18
		A	1.191	0.000	0.000	9.394	0.000	0.08
		B		0.000	0.000	17.912	0.000	0.15
L25	15.7500-15.5000	C		0.000	0.000	7.156	0.000	0.08
		A	1.183	0.000	0.000	1.340	0.000	0.01
		B		0.000	0.000	2.554	0.000	0.02
L26	15.5000-12.2500	C		0.000	0.000	1.021	0.000	0.01
		A	1.169	0.000	0.000	17.377	0.000	0.14
		B		0.000	0.000	33.099	0.000	0.27
L27	12.2500-12.0000	C		0.000	0.000	13.241	0.000	0.14
		A	1.154	0.000	0.000	1.333	0.000	0.01
		B		0.000	0.000	2.537	0.000	0.02
L28	12.0000-11.7500	C		0.000	0.000	1.016	0.000	0.01
		A	1.151	0.000	0.000	1.332	0.000	0.01
		B		0.000	0.000	2.535	0.000	0.02
L29	11.7500-11.5000	C		0.000	0.000	1.015	0.000	0.01
		A	1.149	0.000	0.000	1.332	0.000	0.01
		B		0.000	0.000	2.534	0.000	0.02
L30	11.5000-6.5000	C		0.000	0.000	1.015	0.000	0.01
		A	1.120	0.000	0.000	22.594	0.000	0.17
		B		0.000	0.000	50.325	0.000	0.39
L31	6.5000-6.0000	C		0.000	0.000	17.451	0.000	0.18
		A	1.080	0.000	0.000	2.077	0.000	0.02
		B		0.000	0.000	4.985	0.000	0.04
L32	6.0000-5.7500	C		0.000	0.000	1.323	0.000	0.01
		A	1.073	0.000	0.000	1.037	0.000	0.01
		B		0.000	0.000	2.488	0.000	0.02
L33	5.7500-4.5000	C		0.000	0.000	0.661	0.000	0.01
		A	1.058	0.000	0.000	5.170	0.000	0.04
		B		0.000	0.000	12.398	0.000	0.09
L34	4.5000-4.2500	C		0.000	0.000	3.295	0.000	0.04
		A	1.042	0.000	0.000	1.031	0.000	0.01
		B		0.000	0.000	2.470	0.000	0.02
L35	4.2500-3.0000	C		0.000	0.000	0.657	0.000	0.01
		A	1.022	0.000	0.000	3.930	0.000	0.03
		B		0.000	0.000	11.085	0.000	0.08
L36	3.0000-2.7500	C		0.000	0.000	3.272	0.000	0.04
		A	0.999	0.000	0.000	0.722	0.000	0.01
		B		0.000	0.000	2.144	0.000	0.02

Tower Section	Tower Elevation	Face or Leg	Ice Thickness	A _R	A _F	C _A A _A In Face	C _A A _A Out Face	Weight
n	ft		in	ft ²	ft ²	ft ²	ft ²	K
L37	2.7500-1.7500	C	0.975	0.000	0.000	0.651	0.000	0.01
		A		0.000	0.000	2.874	0.000	0.02
		B		0.000	0.000	7.981	0.000	0.06
L38	1.7500-1.5000	C	0.944	0.000	0.000	2.052	0.000	0.02
		A		0.000	0.000	0.380	0.000	0.00
		B		0.000	0.000	1.510	0.000	0.01
L39	1.5000-1.2500	C	0.928	0.000	0.000	0.047	0.000	0.00
		A		0.000	0.000	0.082	0.000	0.00
		B		0.000	0.000	0.910	0.000	0.01
L40	1.2500-1.0000	C	0.909	0.000	0.000	0.046	0.000	0.00
		A		0.000	0.000	0.081	0.000	0.00
		B		0.000	0.000	0.904	0.000	0.01
L41	1.0000-0.0000	C	0.839	0.000	0.000	0.045	0.000	0.00
		A		0.000	0.000	0.309	0.000	0.00
		B		0.000	0.000	2.890	0.000	0.02
		C		0.000	0.000	0.168	0.000	0.01

Feed Line Center of Pressure

Section	Elevation	CP _x	CP _z	CP _x	CP _z
	ft	in	in	Ice in	Ice in
L1	100.0000-95.0000	0.00	0.00	0.00	0.00
L2	95.0000-90.0000	0.91	-3.19	0.98	-3.29
L3	90.0000-85.5000	0.65	-2.28	0.83	-2.77
L4	85.5000-85.2500	0.47	-1.63	0.70	-2.34
L5	85.2500-80.2500	0.32	-1.24	0.86	-1.71
L6	80.2500-75.2500	-0.01	-0.42	0.63	-1.00
L7	75.2500-70.2500	-0.14	-0.44	0.41	-1.06
L8	70.2500-62.5000	-0.22	-0.35	0.29	-0.96
L9	62.5000-61.5000	-0.23	-0.35	0.29	-0.97
L10	61.5000-56.5000	-0.22	-0.34	0.29	-0.97
L11	56.5000-54.7500	-0.22	-0.32	0.28	-0.95
L12	54.7500-54.5000	-0.22	-0.33	0.28	-0.96
L13	54.5000-49.5000	-0.22	-0.33	0.28	-0.97
L14	49.5000-44.5000	-0.23	-0.33	0.29	-0.99
L15	44.5000-39.5000	-0.24	-0.34	0.29	-1.01
L16	39.5000-34.5000	-0.24	-0.47	0.29	-1.13
L17	34.5000-29.0000	-0.21	-0.79	0.26	-1.33
L18	29.0000-28.0000	-0.20	-0.27	0.24	-0.86
L19	28.0000-23.5000	-0.38	-0.36	0.06	-0.89
L20	23.5000-23.2500	-0.57	-0.46	-0.14	-0.92
L21	23.2500-22.7500	-0.57	-0.46	-0.14	-0.92
L22	22.7500-22.5000	-0.57	-0.46	-0.14	-0.92
L23	22.5000-17.5000	-0.60	-0.15	-0.17	-0.67
L24	17.5000-15.7500	-0.64	0.52	-0.22	-0.09
L25	15.7500-15.5000	-0.64	0.52	-0.23	-0.09
L26	15.5000-12.2500	-0.65	0.52	-0.23	-0.09
L27	12.2500-12.0000	-0.66	0.53	-0.24	-0.08
L28	12.0000-11.7500	-0.66	0.53	-0.24	-0.08
L29	11.7500-11.5000	-0.66	0.53	-0.24	-0.08
L30	11.5000-6.5000	-1.05	0.90	-0.56	0.24
L31	6.5000-6.0000	-1.69	0.79	-1.09	0.12
L32	6.0000-5.7500	-1.70	0.79	-1.10	0.12
L33	5.7500-4.5000	-1.70	0.79	-1.10	0.13
L34	4.5000-4.2500	-1.71	0.80	-1.11	0.14
L35	4.2500-3.0000	-2.29	0.17	-1.56	-0.47
L36	3.0000-2.7500	-2.46	-0.02	-1.70	-0.64
L37	2.7500-1.7500	-2.66	-0.63	-1.84	-1.22
L38	1.7500-1.5000	-2.11	-2.59	-1.07	-2.99
L39	1.5000-1.2500	-2.60	-7.24	-0.78	-5.84
L40	1.2500-1.0000	-2.60	-7.25	-0.79	-5.85
L41	1.0000-0.0000	-1.18	-6.07	0.14	-5.06

Note: For pole sections, center of pressure calculations do not consider feed line shielding.

Shielding Factor Ka

Tower Section	Feed Line Record No.	Description	Feed Line Segment Elev.	K _a No Ice	K _a Ice
L2	5	MLE HYBRID 9POWER/18FIBER RL 2(1-5/8)	90.00 - 94.00	1.0000	1.0000
L2	6	FXL 780 PE(7/8)	90.00 - 94.00	1.0000	1.0000
L2	7	FXL 780 PE(7/8)	90.00 - 94.00	1.0000	1.0000
L2	8	LDF1-50A(1/4)	90.00 - 94.00	1.0000	1.0000
L3	5	MLE HYBRID 9POWER/18FIBER RL 2(1-5/8)	85.50 - 90.00	1.0000	1.0000
L3	6	FXL 780 PE(7/8)	85.50 - 90.00	1.0000	1.0000
L3	7	FXL 780 PE(7/8)	85.50 - 90.00	1.0000	1.0000
L3	8	LDF1-50A(1/4)	85.50 - 90.00	1.0000	1.0000
L3	25	MP3-05	85.50 - 88.00	1.0000	1.0000
L3	26	MP3-05	85.50 - 88.00	1.0000	1.0000
L3	27	MP3-05	85.50 - 88.00	1.0000	1.0000
L4	5	MLE HYBRID 9POWER/18FIBER RL 2(1-5/8)	85.25 - 85.50	1.0000	1.0000
L4	6	FXL 780 PE(7/8)	85.25 - 85.50	1.0000	1.0000
L4	7	FXL 780 PE(7/8)	85.25 - 85.50	1.0000	1.0000
L4	8	LDF1-50A(1/4)	85.25 - 85.50	1.0000	1.0000
L4	25	MP3-05	85.25 - 85.50	1.0000	1.0000
L4	26	MP3-05	85.25 - 85.50	1.0000	1.0000
L4	27	MP3-05	85.25 - 85.50	1.0000	1.0000
L5	5	MLE HYBRID 9POWER/18FIBER RL 2(1-5/8)	80.25 - 85.25	1.0000	1.0000
L5	6	FXL 780 PE(7/8)	80.25 - 85.25	1.0000	1.0000
L5	7	FXL 780 PE(7/8)	80.25 - 85.25	1.0000	1.0000
L5	8	LDF1-50A(1/4)	80.25 - 85.25	1.0000	1.0000
L5	10	CR 50 1070(7/8)	80.25 - 84.00	1.0000	1.0000
L5	11	FB-L98B-034-XXX(3/8)	80.25 - 84.00	1.0000	1.0000
L5	25	MP3-05	80.25 - 85.25	1.0000	1.0000
L5	26	MP3-05	80.25 - 85.25	1.0000	1.0000
L5	27	MP3-05	80.25 - 85.25	1.0000	1.0000

Tower Section	Feed Line Record No.	Description	Feed Line Segment Elev.	K _a No Ice	K _a Ice
L5	35	5 x 1.25	80.25 - 81.50	1.0000	1.0000
L5	36	5 x 1.25	80.25 - 81.50	1.0000	1.0000
L5	37	5 x 1.25	80.25 - 81.50	1.0000	1.0000
L6	5	MLE HYBRID 9POWER/18FIBER RL 2(1-5/8)	75.25 - 80.25	1.0000	1.0000
L6	6	FXL 780 PE(7/8)	75.25 - 80.25	1.0000	1.0000
L6	7	FXL 780 PE(7/8)	75.25 - 80.25	1.0000	1.0000
L6	8	LDF1-50A(1/4)	75.25 - 80.25	1.0000	1.0000
L6	10	CR 50 1070(7/8)	75.25 - 80.25	1.0000	1.0000
L6	11	FB-L98B-034-XXX(3/8)	75.25 - 80.25	1.0000	1.0000
L6	25	MP3-05	75.25 - 80.25	1.0000	1.0000
L6	26	MP3-05	75.25 - 80.25	1.0000	1.0000
L6	27	MP3-05	75.25 - 80.25	1.0000	1.0000
L6	35	5 x 1.25	75.25 - 80.25	1.0000	1.0000
L6	36	5 x 1.25	75.25 - 80.25	1.0000	1.0000
L6	37	5 x 1.25	75.25 - 80.25	1.0000	1.0000
L7	5	MLE HYBRID 9POWER/18FIBER RL 2(1-5/8)	70.25 - 75.25	1.0000	1.0000
L7	6	FXL 780 PE(7/8)	70.25 - 75.25	1.0000	1.0000
L7	7	FXL 780 PE(7/8)	70.25 - 75.25	1.0000	1.0000
L7	8	LDF1-50A(1/4)	70.25 - 75.25	1.0000	1.0000
L7	10	CR 50 1070(7/8)	70.25 - 75.25	1.0000	1.0000
L7	11	FB-L98B-034-XXX(3/8)	70.25 - 75.25	1.0000	1.0000
L7	16	CU12PSM9P8XXX(1-3/8)	70.25 - 74.00	1.0000	1.0000
L7	25	MP3-05	70.25 - 75.25	1.0000	1.0000
L7	26	MP3-05	70.25 - 75.25	1.0000	1.0000
L7	27	MP3-05	70.25 - 75.25	1.0000	1.0000
L7	32	Stacked Plate	70.25 - 71.50	1.0000	1.0000
L7	33	Stacked Plate	70.25 - 71.50	1.0000	1.0000
L7	34	Stacked Plate	70.25 - 71.50	1.0000	1.0000
L7	35	5 x 1.25	71.50 - 75.25	1.0000	1.0000
L7	36	5 x 1.25	71.50 - 75.25	1.0000	1.0000
L7	37	5 x 1.25	71.50 - 75.25	1.0000	1.0000
L8	5	MLE HYBRID 9POWER/18FIBER RL 2(1-5/8)	62.50 - 70.25	1.0000	1.0000
L8	6	FXL 780 PE(7/8)	62.50 - 70.25	1.0000	1.0000

Tower Section	Feed Line Record No.	Description	Feed Line Segment Elev.	K _a No Ice	K _a Ice
L8	7	FXL 780 PE(7/8)	62.50 - 70.25	1.0000	1.0000
L8	8	LDF1-50A(1/4)	62.50 - 70.25	1.0000	1.0000
L8	10	CR 50 1070(7/8)	62.50 - 70.25	1.0000	1.0000
L8	11	FB-L98B-034-XXX(3/8)	62.50 - 70.25	1.0000	1.0000
L8	16	CU12PSM9P8XXX(1-3/8)	62.50 - 70.25	1.0000	1.0000
L8	25	MP3-05	62.50 - 70.25	1.0000	1.0000
L8	26	MP3-05	62.50 - 70.25	1.0000	1.0000
L8	27	MP3-05	62.50 - 70.25	1.0000	1.0000
L8	32	Stacked Plate	62.50 - 70.25	1.0000	1.0000
L8	33	Stacked Plate	62.50 - 70.25	1.0000	1.0000
L8	34	Stacked Plate	62.50 - 70.25	1.0000	1.0000
L9	5	MLE HYBRID 9POWER/18FIBER RL 2(1-5/8)	61.50 - 62.50	1.0000	1.0000
L9	6	FXL 780 PE(7/8)	61.50 - 62.50	1.0000	1.0000
L9	7	FXL 780 PE(7/8)	61.50 - 62.50	1.0000	1.0000
L9	8	LDF1-50A(1/4)	61.50 - 62.50	1.0000	1.0000
L9	10	CR 50 1070(7/8)	61.50 - 62.50	1.0000	1.0000
L9	11	FB-L98B-034-XXX(3/8)	61.50 - 62.50	1.0000	1.0000
L9	16	CU12PSM9P8XXX(1-3/8)	61.50 - 62.50	1.0000	1.0000
L9	25	MP3-05	61.50 - 62.50	1.0000	1.0000
L9	26	MP3-05	61.50 - 62.50	1.0000	1.0000
L9	27	MP3-05	61.50 - 62.50	1.0000	1.0000
L9	32	Stacked Plate	61.50 - 62.50	1.0000	1.0000
L9	33	Stacked Plate	61.50 - 62.50	1.0000	1.0000
L9	34	Stacked Plate	61.50 - 62.50	1.0000	1.0000
L10	5	MLE HYBRID 9POWER/18FIBER RL 2(1-5/8)	56.50 - 61.50	1.0000	1.0000
L10	6	FXL 780 PE(7/8)	56.50 - 61.50	1.0000	1.0000
L10	7	FXL 780 PE(7/8)	56.50 - 61.50	1.0000	1.0000
L10	8	LDF1-50A(1/4)	56.50 - 61.50	1.0000	1.0000
L10	10	CR 50 1070(7/8)	56.50 - 61.50	1.0000	1.0000
L10	11	FB-L98B-034-XXX(3/8)	56.50 - 61.50	1.0000	1.0000
L10	16	CU12PSM9P8XXX(1-3/8)	56.50 - 61.50	1.0000	1.0000
L10	18	MP3-06	56.50 - 58.00	1.0000	1.0000
L10	19	MP3-06	56.50 - 58.00	1.0000	1.0000

Tower Section	Feed Line Record No.	Description	Feed Line Segment Elev.	K _a No Ice	K _a Ice
L10	21	MP3-06	56.50 - 58.00	1.0000	1.0000
L10	25	MP3-05	58.00 - 61.50	1.0000	1.0000
L10	26	MP3-05	58.00 - 61.50	1.0000	1.0000
L10	27	MP3-05	58.00 - 61.50	1.0000	1.0000
L10	32	Stacked Plate	56.50 - 61.50	1.0000	1.0000
L10	33	Stacked Plate	56.50 - 61.50	1.0000	1.0000
L10	34	Stacked Plate	56.50 - 61.50	1.0000	1.0000
L11	5	MLE HYBRID 9POWER/18FIBER RL 2(1-5/8)	54.75 - 56.50	1.0000	1.0000
L11	6	FXL 780 PE(7/8)	54.75 - 56.50	1.0000	1.0000
L11	7	FXL 780 PE(7/8)	54.75 - 56.50	1.0000	1.0000
L11	8	LDF1-50A(1/4)	54.75 - 56.50	1.0000	1.0000
L11	10	CR 50 1070(7/8)	54.75 - 56.50	1.0000	1.0000
L11	11	FB-L98B-034-XXX(3/8)	54.75 - 56.50	1.0000	1.0000
L11	16	CU12PSM9P8XXX(1-3/8)	54.75 - 56.50	1.0000	1.0000
L11	18	MP3-06	54.75 - 56.50	1.0000	1.0000
L11	19	MP3-06	54.75 - 56.50	1.0000	1.0000
L11	21	MP3-06	54.75 - 56.50	1.0000	1.0000
L11	32	Stacked Plate	54.75 - 56.50	1.0000	1.0000
L11	33	Stacked Plate	54.75 - 56.50	1.0000	1.0000
L11	34	Stacked Plate	54.75 - 56.50	1.0000	1.0000
L12	5	MLE HYBRID 9POWER/18FIBER RL 2(1-5/8)	54.50 - 54.75	1.0000	1.0000
L12	6	FXL 780 PE(7/8)	54.50 - 54.75	1.0000	1.0000
L12	7	FXL 780 PE(7/8)	54.50 - 54.75	1.0000	1.0000
L12	8	LDF1-50A(1/4)	54.50 - 54.75	1.0000	1.0000
L12	10	CR 50 1070(7/8)	54.50 - 54.75	1.0000	1.0000
L12	11	FB-L98B-034-XXX(3/8)	54.50 - 54.75	1.0000	1.0000
L12	16	CU12PSM9P8XXX(1-3/8)	54.50 - 54.75	1.0000	1.0000
L12	18	MP3-06	54.50 - 54.75	1.0000	1.0000
L12	19	MP3-06	54.50 - 54.75	1.0000	1.0000
L12	21	MP3-06	54.50 - 54.75	1.0000	1.0000
L12	32	Stacked Plate	54.50 - 54.75	1.0000	1.0000
L12	33	Stacked Plate	54.50 - 54.75	1.0000	1.0000
L12	34	Stacked Plate	54.50 - 54.75	1.0000	1.0000

Tower Section	Feed Line Record No.	Description	Feed Line Segment Elev.	K _a No Ice	K _a Ice
L13	5	MLE HYBRID 9POWER/18FIBER RL 2(1-5/8)	49.50 - 54.50	1.0000	1.0000
L13	6	FXL 780 PE(7/8)	49.50 - 54.50	1.0000	1.0000
L13	7	FXL 780 PE(7/8)	49.50 - 54.50	1.0000	1.0000
L13	8	LDF1-50A(1/4)	49.50 - 54.50	1.0000	1.0000
L13	10	CR 50 1070(7/8)	49.50 - 54.50	1.0000	1.0000
L13	11	FB-L98B-034-XXX(3/8)	49.50 - 54.50	1.0000	1.0000
L13	16	CU12PSM9P8XXX(1-3/8)	49.50 - 54.50	1.0000	1.0000
L13	18	MP3-06	49.50 - 54.50	1.0000	1.0000
L13	19	MP3-06	49.50 - 54.50	1.0000	1.0000
L13	21	MP3-06	49.50 - 54.50	1.0000	1.0000
L13	32	Stacked Plate	49.50 - 54.50	1.0000	1.0000
L13	33	Stacked Plate	49.50 - 54.50	1.0000	1.0000
L13	34	Stacked Plate	49.50 - 54.50	1.0000	1.0000
L14	5	MLE HYBRID 9POWER/18FIBER RL 2(1-5/8)	44.50 - 49.50	1.0000	1.0000
L14	6	FXL 780 PE(7/8)	44.50 - 49.50	1.0000	1.0000
L14	7	FXL 780 PE(7/8)	44.50 - 49.50	1.0000	1.0000
L14	8	LDF1-50A(1/4)	44.50 - 49.50	1.0000	1.0000
L14	10	CR 50 1070(7/8)	44.50 - 49.50	1.0000	1.0000
L14	11	FB-L98B-034-XXX(3/8)	44.50 - 49.50	1.0000	1.0000
L14	16	CU12PSM9P8XXX(1-3/8)	44.50 - 49.50	1.0000	1.0000
L14	18	MP3-06	44.50 - 49.50	1.0000	1.0000
L14	19	MP3-06	44.50 - 49.50	1.0000	1.0000
L14	21	MP3-06	44.50 - 49.50	1.0000	1.0000
L14	32	Stacked Plate	44.50 - 49.50	1.0000	1.0000
L14	33	Stacked Plate	44.50 - 49.50	1.0000	1.0000
L14	34	Stacked Plate	44.50 - 49.50	1.0000	1.0000
L15	5	MLE HYBRID 9POWER/18FIBER RL 2(1-5/8)	39.50 - 44.50	1.0000	1.0000
L15	6	FXL 780 PE(7/8)	39.50 - 44.50	1.0000	1.0000
L15	7	FXL 780 PE(7/8)	39.50 - 44.50	1.0000	1.0000
L15	8	LDF1-50A(1/4)	39.50 - 44.50	1.0000	1.0000
L15	10	CR 50 1070(7/8)	39.50 - 44.50	1.0000	1.0000
L15	11	FB-L98B-034-XXX(3/8)	39.50 - 44.50	1.0000	1.0000
L15	16	CU12PSM9P8XXX(1-3/8)	39.50 - 44.50	1.0000	1.0000

Tower Section	Feed Line Record No.	Description	Feed Line Segment Elev.	K _a No Ice	K _a Ice
L15	18	MP3-06	39.50 - 44.50	1.0000	1.0000
L15	19	MP3-06	39.50 - 44.50	1.0000	1.0000
L15	21	MP3-06	39.50 - 44.50	1.0000	1.0000
L15	32	Stacked Plate	39.50 - 44.50	1.0000	1.0000
L15	33	Stacked Plate	39.50 - 44.50	1.0000	1.0000
L15	34	Stacked Plate	39.50 - 44.50	1.0000	1.0000
L16	5	MLE HYBRID 9POWER/18FIBER RL 2(1-5/8)	34.50 - 39.50	1.0000	1.0000
L16	6	FXL 780 PE(7/8)	34.50 - 39.50	1.0000	1.0000
L16	7	FXL 780 PE(7/8)	34.50 - 39.50	1.0000	1.0000
L16	8	LDF1-50A(1/4)	34.50 - 39.50	1.0000	1.0000
L16	10	CR 50 1070(7/8)	34.50 - 39.50	1.0000	1.0000
L16	11	FB-L98B-034-XXX(3/8)	34.50 - 39.50	1.0000	1.0000
L16	16	CU12PSM9P8XXX(1-3/8)	34.50 - 39.50	1.0000	1.0000
L16	18	MP3-06	34.50 - 39.50	1.0000	1.0000
L16	19	MP3-06	34.50 - 39.50	1.0000	1.0000
L16	21	MP3-06	34.50 - 39.50	1.0000	1.0000
L16	22	MP3-05	34.50 - 35.00	1.0000	1.0000
L16	32	Stacked Plate	34.50 - 39.50	1.0000	1.0000
L16	33	Stacked Plate	34.50 - 39.50	1.0000	1.0000
L16	34	Stacked Plate	34.50 - 39.50	1.0000	1.0000
L17	5	MLE HYBRID 9POWER/18FIBER RL 2(1-5/8)	29.00 - 34.50	1.0000	1.0000
L17	6	FXL 780 PE(7/8)	29.00 - 34.50	1.0000	1.0000
L17	7	FXL 780 PE(7/8)	29.00 - 34.50	1.0000	1.0000
L17	8	LDF1-50A(1/4)	29.00 - 34.50	1.0000	1.0000
L17	10	CR 50 1070(7/8)	29.00 - 34.50	1.0000	1.0000
L17	11	FB-L98B-034-XXX(3/8)	29.00 - 34.50	1.0000	1.0000
L17	16	CU12PSM9P8XXX(1-3/8)	29.00 - 34.50	1.0000	1.0000
L17	18	MP3-06	29.00 - 34.50	1.0000	1.0000
L17	19	MP3-06	29.00 - 34.50	1.0000	1.0000
L17	21	MP3-06	29.00 - 34.50	1.0000	1.0000
L17	22	MP3-05	29.00 - 34.50	1.0000	1.0000
L17	23	MP3-05	29.00 - 32.00	1.0000	1.0000
L17	24	MP3-05	29.00 - 32.00	1.0000	1.0000

Tower Section	Feed Line Record No.	Description	Feed Line Segment Elev.	K _a No Ice	K _a Ice
L17	32	Stacked Plate	29.00 - 34.50	1.0000	1.0000
L17	33	Stacked Plate	29.00 - 34.50	1.0000	1.0000
L17	34	Stacked Plate	29.00 - 34.50	1.0000	1.0000
L18	5	MLE HYBRID 9POWER/18FIBER RL 2(1-5/8)	28.00 - 29.00	1.0000	1.0000
L18	6	FXL 780 PE(7/8)	28.00 - 29.00	1.0000	1.0000
L18	7	FXL 780 PE(7/8)	28.00 - 29.00	1.0000	1.0000
L18	8	LDF1-50A(1/4)	28.00 - 29.00	1.0000	1.0000
L18	10	CR 50 1070(7/8)	28.00 - 29.00	1.0000	1.0000
L18	11	FB-L98B-034-XXX(3/8)	28.00 - 29.00	1.0000	1.0000
L18	16	CU12PSM9P8XXX(1-3/8)	28.00 - 29.00	1.0000	1.0000
L18	18	MP3-06	28.00 - 29.00	1.0000	1.0000
L18	19	MP3-06	28.00 - 29.00	1.0000	1.0000
L18	21	MP3-06	28.00 - 29.00	1.0000	1.0000
L18	22	MP3-05	28.00 - 29.00	1.0000	1.0000
L18	23	MP3-05	28.00 - 29.00	1.0000	1.0000
L18	24	MP3-05	28.00 - 29.00	1.0000	1.0000
L18	32	Stacked Plate	28.00 - 29.00	1.0000	1.0000
L18	33	Stacked Plate	28.00 - 29.00	1.0000	1.0000
L18	34	Stacked Plate	28.00 - 29.00	1.0000	1.0000
L19	5	MLE HYBRID 9POWER/18FIBER RL 2(1-5/8)	23.50 - 28.00	1.0000	1.0000
L19	6	FXL 780 PE(7/8)	23.50 - 28.00	1.0000	1.0000
L19	7	FXL 780 PE(7/8)	23.50 - 28.00	1.0000	1.0000
L19	8	LDF1-50A(1/4)	23.50 - 28.00	1.0000	1.0000
L19	10	CR 50 1070(7/8)	23.50 - 28.00	1.0000	1.0000
L19	11	FB-L98B-034-XXX(3/8)	23.50 - 28.00	1.0000	1.0000
L19	16	CU12PSM9P8XXX(1-3/8)	23.50 - 28.00	1.0000	1.0000
L19	18	MP3-06	23.50 - 28.00	1.0000	1.0000
L19	19	MP3-06	23.50 - 28.00	1.0000	1.0000
L19	21	MP3-06	23.50 - 28.00	1.0000	1.0000
L19	22	MP3-05	23.50 - 28.00	1.0000	1.0000
L19	23	MP3-05	23.50 - 28.00	1.0000	1.0000
L19	24	MP3-05	23.50 - 28.00	1.0000	1.0000
L19	28	CCI-065125	23.50 - 25.50	1.0000	1.0000

Tower Section	Feed Line Record No.	Description	Feed Line Segment Elev.	K _a No Ice	K _a Ice
L19	29	CCI-060100	23.50 - 25.50	1.0000	1.0000
L19	30	CCI-060100	23.50 - 25.50	1.0000	1.0000
L19	32	Stacked Plate	23.50 - 28.00	1.0000	1.0000
L19	33	Stacked Plate	23.50 - 28.00	1.0000	1.0000
L19	34	Stacked Plate	23.50 - 28.00	1.0000	1.0000
L20	5	MLE HYBRID 9POWER/18FIBER RL 2(1-5/8)	23.25 - 23.50	1.0000	1.0000
L20	6	FXL 780 PE(7/8)	23.25 - 23.50	1.0000	1.0000
L20	7	FXL 780 PE(7/8)	23.25 - 23.50	1.0000	1.0000
L20	8	LDF1-50A(1/4)	23.25 - 23.50	1.0000	1.0000
L20	10	CR 50 1070(7/8)	23.25 - 23.50	1.0000	1.0000
L20	11	FB-L98B-034-XXX(3/8)	23.25 - 23.50	1.0000	1.0000
L20	16	CU12PSM9P8XXX(1-3/8)	23.25 - 23.50	1.0000	1.0000
L20	18	MP3-06	23.25 - 23.50	1.0000	1.0000
L20	19	MP3-06	23.25 - 23.50	1.0000	1.0000
L20	21	MP3-06	23.25 - 23.50	1.0000	1.0000
L20	22	MP3-05	23.25 - 23.50	1.0000	1.0000
L20	23	MP3-05	23.25 - 23.50	1.0000	1.0000
L20	24	MP3-05	23.25 - 23.50	1.0000	1.0000
L20	28	CCI-065125	23.25 - 23.50	1.0000	1.0000
L20	29	CCI-060100	23.25 - 23.50	1.0000	1.0000
L20	30	CCI-060100	23.25 - 23.50	1.0000	1.0000
L20	32	Stacked Plate	23.25 - 23.50	1.0000	1.0000
L20	33	Stacked Plate	23.25 - 23.50	1.0000	1.0000
L20	34	Stacked Plate	23.25 - 23.50	1.0000	1.0000
L21	5	MLE HYBRID 9POWER/18FIBER RL 2(1-5/8)	22.75 - 23.25	1.0000	1.0000
L21	6	FXL 780 PE(7/8)	22.75 - 23.25	1.0000	1.0000
L21	7	FXL 780 PE(7/8)	22.75 - 23.25	1.0000	1.0000
L21	8	LDF1-50A(1/4)	22.75 - 23.25	1.0000	1.0000
L21	10	CR 50 1070(7/8)	22.75 - 23.25	1.0000	1.0000
L21	11	FB-L98B-034-XXX(3/8)	22.75 - 23.25	1.0000	1.0000
L21	16	CU12PSM9P8XXX(1-3/8)	22.75 - 23.25	1.0000	1.0000
L21	18	MP3-06	22.75 - 23.25	1.0000	1.0000
L21	19	MP3-06	22.75 - 23.25	1.0000	1.0000

Tower Section	Feed Line Record No.	Description	Feed Line Segment Elev.	K _a No Ice	K _a Ice
L21	21	MP3-06	22.75 - 23.25	1.0000	1.0000
L21	22	MP3-05	22.75 - 23.25	1.0000	1.0000
L21	23	MP3-05	22.75 - 23.25	1.0000	1.0000
L21	24	MP3-05	22.75 - 23.25	1.0000	1.0000
L21	28	CCI-065125	22.75 - 23.25	1.0000	1.0000
L21	29	CCI-060100	22.75 - 23.25	1.0000	1.0000
L21	30	CCI-060100	22.75 - 23.25	1.0000	1.0000
L21	32	Stacked Plate	22.75 - 23.25	1.0000	1.0000
L21	33	Stacked Plate	22.75 - 23.25	1.0000	1.0000
L21	34	Stacked Plate	22.75 - 23.25	1.0000	1.0000
L22	5	MLE HYBRID 9POWER/18FIBER RL 2(1-5/8)	22.50 - 22.75	1.0000	1.0000
L22	6	FXL 780 PE(7/8)	22.50 - 22.75	1.0000	1.0000
L22	7	FXL 780 PE(7/8)	22.50 - 22.75	1.0000	1.0000
L22	8	LDF1-50A(1/4)	22.50 - 22.75	1.0000	1.0000
L22	10	CR 50 1070(7/8)	22.50 - 22.75	1.0000	1.0000
L22	11	FB-L98B-034-XXX(3/8)	22.50 - 22.75	1.0000	1.0000
L22	16	CU12PSM9P8XXX(1-3/8)	22.50 - 22.75	1.0000	1.0000
L22	18	MP3-06	22.50 - 22.75	1.0000	1.0000
L22	19	MP3-06	22.50 - 22.75	1.0000	1.0000
L22	21	MP3-06	22.50 - 22.75	1.0000	1.0000
L22	22	MP3-05	22.50 - 22.75	1.0000	1.0000
L22	23	MP3-05	22.50 - 22.75	1.0000	1.0000
L22	24	MP3-05	22.50 - 22.75	1.0000	1.0000
L22	28	CCI-065125	22.50 - 22.75	1.0000	1.0000
L22	29	CCI-060100	22.50 - 22.75	1.0000	1.0000
L22	30	CCI-060100	22.50 - 22.75	1.0000	1.0000
L22	32	Stacked Plate	22.50 - 22.75	1.0000	1.0000
L22	33	Stacked Plate	22.50 - 22.75	1.0000	1.0000
L22	34	Stacked Plate	22.50 - 22.75	1.0000	1.0000
L23	5	MLE HYBRID 9POWER/18FIBER RL 2(1-5/8)	17.50 - 22.50	1.0000	1.0000
L23	6	FXL 780 PE(7/8)	17.50 - 22.50	1.0000	1.0000
L23	7	FXL 780 PE(7/8)	17.50 - 22.50	1.0000	1.0000
L23	8	LDF1-50A(1/4)	17.50 - 22.50	1.0000	1.0000

Tower Section	Feed Line Record No.	Description	Feed Line Segment Elev.	K _a No Ice	K _a Ice
L23	10	CR 50 1070(7/8)	17.50 - 22.50	1.0000	1.0000
L23	11	FB-L98B-034-XXX(3/8)	17.50 - 22.50	1.0000	1.0000
L23	16	CU12PSM9P8XXX(1-3/8)	17.50 - 22.50	1.0000	1.0000
L23	18	MP3-06	17.50 - 22.50	1.0000	1.0000
L23	19	MP3-06	17.50 - 22.50	1.0000	1.0000
L23	20	MP3-06	17.50 - 19.00	1.0000	1.0000
L23	21	MP3-06	17.50 - 22.50	1.0000	1.0000
L23	22	MP3-05	17.50 - 22.50	1.0000	1.0000
L23	23	MP3-05	17.50 - 22.50	1.0000	1.0000
L23	24	MP3-05	17.50 - 22.50	1.0000	1.0000
L23	28	CCI-065125	17.50 - 22.50	1.0000	1.0000
L23	29	CCI-060100	17.50 - 22.50	1.0000	1.0000
L23	30	CCI-060100	17.50 - 22.50	1.0000	1.0000
L23	32	Stacked Plate	17.50 - 22.50	1.0000	1.0000
L23	33	Stacked Plate	17.50 - 22.50	1.0000	1.0000
L23	34	Stacked Plate	17.50 - 22.50	1.0000	1.0000
L24	5	MLE HYBRID 9POWER/18FIBER RL 2(1-5/8)	15.75 - 17.50	1.0000	1.0000
L24	6	FXL 780 PE(7/8)	15.75 - 17.50	1.0000	1.0000
L24	7	FXL 780 PE(7/8)	15.75 - 17.50	1.0000	1.0000
L24	8	LDF1-50A(1/4)	15.75 - 17.50	1.0000	1.0000
L24	10	CR 50 1070(7/8)	15.75 - 17.50	1.0000	1.0000
L24	11	FB-L98B-034-XXX(3/8)	15.75 - 17.50	1.0000	1.0000
L24	16	CU12PSM9P8XXX(1-3/8)	15.75 - 17.50	1.0000	1.0000
L24	18	MP3-06	15.75 - 17.50	1.0000	1.0000
L24	19	MP3-06	15.75 - 17.50	1.0000	1.0000
L24	20	MP3-06	15.75 - 17.50	1.0000	1.0000
L24	21	MP3-06	15.75 - 17.50	1.0000	1.0000
L24	22	MP3-05	15.75 - 17.50	1.0000	1.0000
L24	23	MP3-05	15.75 - 17.50	1.0000	1.0000
L24	24	MP3-05	15.75 - 17.50	1.0000	1.0000
L24	28	CCI-065125	15.75 - 17.50	1.0000	1.0000
L24	29	CCI-060100	15.75 - 17.50	1.0000	1.0000
L24	30	CCI-060100	15.75 - 17.50	1.0000	1.0000
L24	32	Stacked Plate	15.75 - 17.50	1.0000	1.0000

Tower Section	Feed Line Record No.	Description	Feed Line Segment Elev.	K _a No Ice	K _a Ice
L24	33	Stacked Plate	15.75 - 17.50	1.0000	1.0000
L24	34	Stacked Plate	15.75 - 17.50	1.0000	1.0000
L25	5	MLE HYBRID 9POWER/18FIBER RL 2(1-5/8)	15.50 - 15.75	1.0000	1.0000
L25	6	FXL 780 PE(7/8)	15.50 - 15.75	1.0000	1.0000
L25	7	FXL 780 PE(7/8)	15.50 - 15.75	1.0000	1.0000
L25	8	LDF1-50A(1/4)	15.50 - 15.75	1.0000	1.0000
L25	10	CR 50 1070(7/8)	15.50 - 15.75	1.0000	1.0000
L25	11	FB-L98B-034-XXX(3/8)	15.50 - 15.75	1.0000	1.0000
L25	16	CU12PSM9P8XXX(1-3/8)	15.50 - 15.75	1.0000	1.0000
L25	18	MP3-06	15.50 - 15.75	1.0000	1.0000
L25	19	MP3-06	15.50 - 15.75	1.0000	1.0000
L25	20	MP3-06	15.50 - 15.75	1.0000	1.0000
L25	21	MP3-06	15.50 - 15.75	1.0000	1.0000
L25	22	MP3-05	15.50 - 15.75	1.0000	1.0000
L25	23	MP3-05	15.50 - 15.75	1.0000	1.0000
L25	24	MP3-05	15.50 - 15.75	1.0000	1.0000
L25	28	CCI-065125	15.50 - 15.75	1.0000	1.0000
L25	29	CCI-060100	15.50 - 15.75	1.0000	1.0000
L25	30	CCI-060100	15.50 - 15.75	1.0000	1.0000
L25	32	Stacked Plate	15.50 - 15.75	1.0000	1.0000
L25	33	Stacked Plate	15.50 - 15.75	1.0000	1.0000
L25	34	Stacked Plate	15.50 - 15.75	1.0000	1.0000
L26	5	MLE HYBRID 9POWER/18FIBER RL 2(1-5/8)	12.25 - 15.50	1.0000	1.0000
L26	6	FXL 780 PE(7/8)	12.25 - 15.50	1.0000	1.0000
L26	7	FXL 780 PE(7/8)	12.25 - 15.50	1.0000	1.0000
L26	8	LDF1-50A(1/4)	12.25 - 15.50	1.0000	1.0000
L26	10	CR 50 1070(7/8)	12.25 - 15.50	1.0000	1.0000
L26	11	FB-L98B-034-XXX(3/8)	12.25 - 15.50	1.0000	1.0000
L26	16	CU12PSM9P8XXX(1-3/8)	12.25 - 15.50	1.0000	1.0000
L26	18	MP3-06	12.25 - 15.50	1.0000	1.0000
L26	19	MP3-06	12.25 - 15.50	1.0000	1.0000
L26	20	MP3-06	12.25 - 15.50	1.0000	1.0000
L26	21	MP3-06	12.25 - 15.50	1.0000	1.0000

Tower Section	Feed Line Record No.	Description	Feed Line Segment Elev.	K _a No Ice	K _a Ice
L26	22	MP3-05	12.25 - 15.50	1.0000	1.0000
L26	23	MP3-05	12.25 - 15.50	1.0000	1.0000
L26	24	MP3-05	12.25 - 15.50	1.0000	1.0000
L26	28	CCI-065125	12.25 - 15.50	1.0000	1.0000
L26	29	CCI-060100	12.25 - 15.50	1.0000	1.0000
L26	30	CCI-060100	12.25 - 15.50	1.0000	1.0000
L26	32	Stacked Plate	12.25 - 15.50	1.0000	1.0000
L26	33	Stacked Plate	12.25 - 15.50	1.0000	1.0000
L26	34	Stacked Plate	12.25 - 15.50	1.0000	1.0000
L27	5	MLE HYBRID 9POWER/18FIBER RL 2(1-5/8)	12.00 - 12.25	1.0000	1.0000
L27	6	FXL 780 PE(7/8)	12.00 - 12.25	1.0000	1.0000
L27	7	FXL 780 PE(7/8)	12.00 - 12.25	1.0000	1.0000
L27	8	LDF1-50A(1/4)	12.00 - 12.25	1.0000	1.0000
L27	10	CR 50 1070(7/8)	12.00 - 12.25	1.0000	1.0000
L27	11	FB-L98B-034-XXX(3/8)	12.00 - 12.25	1.0000	1.0000
L27	16	CU12PSM9P8XXX(1-3/8)	12.00 - 12.25	1.0000	1.0000
L27	18	MP3-06	12.00 - 12.25	1.0000	1.0000
L27	19	MP3-06	12.00 - 12.25	1.0000	1.0000
L27	20	MP3-06	12.00 - 12.25	1.0000	1.0000
L27	21	MP3-06	12.00 - 12.25	1.0000	1.0000
L27	22	MP3-05	12.00 - 12.25	1.0000	1.0000
L27	23	MP3-05	12.00 - 12.25	1.0000	1.0000
L27	24	MP3-05	12.00 - 12.25	1.0000	1.0000
L27	28	CCI-065125	12.00 - 12.25	1.0000	1.0000
L27	29	CCI-060100	12.00 - 12.25	1.0000	1.0000
L27	30	CCI-060100	12.00 - 12.25	1.0000	1.0000
L27	32	Stacked Plate	12.00 - 12.25	1.0000	1.0000
L27	33	Stacked Plate	12.00 - 12.25	1.0000	1.0000
L27	34	Stacked Plate	12.00 - 12.25	1.0000	1.0000
L28	5	MLE HYBRID 9POWER/18FIBER RL 2(1-5/8)	11.75 - 12.00	1.0000	1.0000
L28	6	FXL 780 PE(7/8)	11.75 - 12.00	1.0000	1.0000
L28	7	FXL 780 PE(7/8)	11.75 - 12.00	1.0000	1.0000
L28	8	LDF1-50A(1/4)	11.75 - 12.00	1.0000	1.0000

Tower Section	Feed Line Record No.	Description	Feed Line Segment Elev.	K _a No Ice	K _a Ice
L28	10	CR 50 1070(7/8)	11.75 - 12.00	1.0000	1.0000
L28	11	FB-L98B-034-XXX(3/8)	11.75 - 12.00	1.0000	1.0000
L28	16	CU12PSM9P8XXX(1-3/8)	11.75 - 12.00	1.0000	1.0000
L28	18	MP3-06	11.75 - 12.00	1.0000	1.0000
L28	19	MP3-06	11.75 - 12.00	1.0000	1.0000
L28	20	MP3-06	11.75 - 12.00	1.0000	1.0000
L28	21	MP3-06	11.75 - 12.00	1.0000	1.0000
L28	22	MP3-05	11.75 - 12.00	1.0000	1.0000
L28	23	MP3-05	11.75 - 12.00	1.0000	1.0000
L28	24	MP3-05	11.75 - 12.00	1.0000	1.0000
L28	28	CCI-065125	11.75 - 12.00	1.0000	1.0000
L28	29	CCI-060100	11.75 - 12.00	1.0000	1.0000
L28	30	CCI-060100	11.75 - 12.00	1.0000	1.0000
L28	32	Stacked Plate	11.75 - 12.00	1.0000	1.0000
L28	33	Stacked Plate	11.75 - 12.00	1.0000	1.0000
L28	34	Stacked Plate	11.75 - 12.00	1.0000	1.0000
L29	5	MLE HYBRID 9POWER/18FIBER RL 2(1-5/8)	11.50 - 11.75	1.0000	1.0000
L29	6	FXL 780 PE(7/8)	11.50 - 11.75	1.0000	1.0000
L29	7	FXL 780 PE(7/8)	11.50 - 11.75	1.0000	1.0000
L29	8	LDF1-50A(1/4)	11.50 - 11.75	1.0000	1.0000
L29	10	CR 50 1070(7/8)	11.50 - 11.75	1.0000	1.0000
L29	11	FB-L98B-034-XXX(3/8)	11.50 - 11.75	1.0000	1.0000
L29	16	CU12PSM9P8XXX(1-3/8)	11.50 - 11.75	1.0000	1.0000
L29	18	MP3-06	11.50 - 11.75	1.0000	1.0000
L29	19	MP3-06	11.50 - 11.75	1.0000	1.0000
L29	20	MP3-06	11.50 - 11.75	1.0000	1.0000
L29	21	MP3-06	11.50 - 11.75	1.0000	1.0000
L29	22	MP3-05	11.50 - 11.75	1.0000	1.0000
L29	23	MP3-05	11.50 - 11.75	1.0000	1.0000
L29	24	MP3-05	11.50 - 11.75	1.0000	1.0000
L29	28	CCI-065125	11.50 - 11.75	1.0000	1.0000
L29	29	CCI-060100	11.50 - 11.75	1.0000	1.0000
L29	30	CCI-060100	11.50 - 11.75	1.0000	1.0000
L29	32	Stacked Plate	11.50 - 11.75	1.0000	1.0000

Tower Section	Feed Line Record No.	Description	Feed Line Segment Elev.	K _a No Ice	K _a Ice
L29	33	Stacked Plate	11.50 - 11.75	1.0000	1.0000
L29	34	Stacked Plate	11.50 - 11.75	1.0000	1.0000
L30	5	MLE HYBRID 9POWER/18FIBER RL 2(1-5/8)	6.50 - 11.50	1.0000	1.0000
L30	6	FXL 780 PE(7/8)	6.50 - 11.50	1.0000	1.0000
L30	7	FXL 780 PE(7/8)	6.50 - 11.50	1.0000	1.0000
L30	8	LDF1-50A(1/4)	6.50 - 11.50	1.0000	1.0000
L30	10	CR 50 1070(7/8)	6.50 - 11.50	1.0000	1.0000
L30	11	FB-L98B-034-XXX(3/8)	6.50 - 11.50	1.0000	1.0000
L30	16	CU12PSM9P8XXX(1-3/8)	6.50 - 11.50	1.0000	1.0000
L30	18	MP3-06	6.50 - 11.50	1.0000	1.0000
L30	19	MP3-06	6.50 - 11.50	1.0000	1.0000
L30	20	MP3-06	6.50 - 11.50	1.0000	1.0000
L30	21	MP3-06	8.50 - 11.50	1.0000	1.0000
L30	22	MP3-05	10.00 - 11.50	1.0000	1.0000
L30	23	MP3-05	6.50 - 11.50	1.0000	1.0000
L30	24	MP3-05	6.50 - 11.50	1.0000	1.0000
L30	28	CCI-065125	6.50 - 11.50	1.0000	1.0000
L30	29	CCI-060100	6.50 - 11.50	1.0000	1.0000
L30	30	CCI-060100	6.50 - 11.50	1.0000	1.0000
L30	32	Stacked Plate	6.50 - 11.50	1.0000	1.0000
L30	33	Stacked Plate	6.50 - 11.50	1.0000	1.0000
L30	34	Stacked Plate	6.50 - 11.50	1.0000	1.0000
L31	5	MLE HYBRID 9POWER/18FIBER RL 2(1-5/8)	6.00 - 6.50	1.0000	1.0000
L31	6	FXL 780 PE(7/8)	6.00 - 6.50	1.0000	1.0000
L31	7	FXL 780 PE(7/8)	6.00 - 6.50	1.0000	1.0000
L31	8	LDF1-50A(1/4)	6.00 - 6.50	1.0000	1.0000
L31	10	CR 50 1070(7/8)	6.00 - 6.50	1.0000	1.0000
L31	11	FB-L98B-034-XXX(3/8)	6.00 - 6.50	1.0000	1.0000
L31	16	CU12PSM9P8XXX(1-3/8)	6.00 - 6.50	1.0000	1.0000
L31	18	MP3-06	6.00 - 6.50	1.0000	1.0000
L31	19	MP3-06	6.00 - 6.50	1.0000	1.0000
L31	20	MP3-06	6.00 - 6.50	1.0000	1.0000
L31	23	MP3-05	6.00 - 6.50	1.0000	1.0000
L31	24	MP3-05	6.00 - 6.50	1.0000	1.0000
L31	28	CCI-065125	6.00 - 6.50	1.0000	1.0000
L31	29	CCI-060100	6.00 - 6.50	1.0000	1.0000
L31	30	CCI-060100	6.00 - 6.50	1.0000	1.0000
L31	32	Stacked Plate	6.00 - 6.50	1.0000	1.0000
L31	33	Stacked Plate	6.00 - 6.50	1.0000	1.0000
L31	34	Stacked Plate	6.00 - 6.50	1.0000	1.0000
L32	5	MLE HYBRID 9POWER/18FIBER RL 2(1-5/8)	5.75 - 6.00	1.0000	1.0000
L32	6	FXL 780 PE(7/8)	5.75 - 6.00	1.0000	1.0000
L32	7	FXL 780 PE(7/8)	5.75 - 6.00	1.0000	1.0000
L32	8	LDF1-50A(1/4)	5.75 - 6.00	1.0000	1.0000
L32	10	CR 50 1070(7/8)	5.75 - 6.00	1.0000	1.0000
L32	11	FB-L98B-034-XXX(3/8)	5.75 - 6.00	1.0000	1.0000
L32	16	CU12PSM9P8XXX(1-3/8)	5.75 - 6.00	1.0000	1.0000
L32	18	MP3-06	5.75 - 6.00	1.0000	1.0000
L32	19	MP3-06	5.75 - 6.00	1.0000	1.0000
L32	20	MP3-06	5.75 - 6.00	1.0000	1.0000
L32	23	MP3-05	5.75 - 6.00	1.0000	1.0000
L32	24	MP3-05	5.75 - 6.00	1.0000	1.0000
L32	28	CCI-065125	5.75 - 6.00	1.0000	1.0000
L32	29	CCI-060100	5.75 - 6.00	1.0000	1.0000
L32	30	CCI-060100	5.75 - 6.00	1.0000	1.0000
L32	32	Stacked Plate	5.75 - 6.00	1.0000	1.0000
L32	33	Stacked Plate	5.75 - 6.00	1.0000	1.0000
L32	34	Stacked Plate	5.75 - 6.00	1.0000	1.0000

Tower Section	Feed Line Record No.	Description	Feed Line Segment Elev.	K _a No Ice	K _a Ice
L33	5	MLE HYBRID 9POWER/18FIBER RL 2(1-5/8)	4.50 - 5.75	1.0000	1.0000
L33	6	FXL 780 PE(7/8)	4.50 - 5.75	1.0000	1.0000
L33	7	FXL 780 PE(7/8)	4.50 - 5.75	1.0000	1.0000
L33	8	LDF1-50A(1/4)	4.50 - 5.75	1.0000	1.0000
L33	10	CR 50 1070(7/8)	4.50 - 5.75	1.0000	1.0000
L33	11	FB-L98B-034-XXX(3/8)	4.50 - 5.75	1.0000	1.0000
L33	16	CU12PSM9P8XXX(1-3/8)	4.50 - 5.75	1.0000	1.0000
L33	18	MP3-06	4.50 - 5.75	1.0000	1.0000
L33	19	MP3-06	4.50 - 5.75	1.0000	1.0000
L33	20	MP3-06	4.50 - 5.75	1.0000	1.0000
L33	23	MP3-05	4.50 - 5.75	1.0000	1.0000
L33	24	MP3-05	4.50 - 5.75	1.0000	1.0000
L33	28	CCI-065125	4.50 - 5.75	1.0000	1.0000
L33	29	CCI-060100	4.50 - 5.75	1.0000	1.0000
L33	30	CCI-060100	4.50 - 5.75	1.0000	1.0000
L33	32	Stacked Plate	4.50 - 5.75	1.0000	1.0000
L33	33	Stacked Plate	4.50 - 5.75	1.0000	1.0000
L33	34	Stacked Plate	4.50 - 5.75	1.0000	1.0000
L34	5	MLE HYBRID 9POWER/18FIBER RL 2(1-5/8)	4.25 - 4.50	1.0000	1.0000
L34	6	FXL 780 PE(7/8)	4.25 - 4.50	1.0000	1.0000
L34	7	FXL 780 PE(7/8)	4.25 - 4.50	1.0000	1.0000
L34	8	LDF1-50A(1/4)	4.25 - 4.50	1.0000	1.0000
L34	10	CR 50 1070(7/8)	4.25 - 4.50	1.0000	1.0000
L34	11	FB-L98B-034-XXX(3/8)	4.25 - 4.50	1.0000	1.0000
L34	16	CU12PSM9P8XXX(1-3/8)	4.25 - 4.50	1.0000	1.0000
L34	18	MP3-06	4.25 - 4.50	1.0000	1.0000
L34	19	MP3-06	4.25 - 4.50	1.0000	1.0000
L34	20	MP3-06	4.25 - 4.50	1.0000	1.0000
L34	23	MP3-05	4.25 - 4.50	1.0000	1.0000
L34	24	MP3-05	4.25 - 4.50	1.0000	1.0000
L34	28	CCI-065125	4.25 - 4.50	1.0000	1.0000
L34	29	CCI-060100	4.25 - 4.50	1.0000	1.0000
L34	30	CCI-060100	4.25 - 4.50	1.0000	1.0000
L34	32	Stacked Plate	4.25 - 4.50	1.0000	1.0000
L34	33	Stacked Plate	4.25 - 4.50	1.0000	1.0000
L34	34	Stacked Plate	4.25 - 4.50	1.0000	1.0000
L35	5	MLE HYBRID 9POWER/18FIBER RL 2(1-5/8)	3.00 - 4.25	1.0000	1.0000
L35	6	FXL 780 PE(7/8)	3.00 - 4.25	1.0000	1.0000
L35	7	FXL 780 PE(7/8)	3.00 - 4.25	1.0000	1.0000
L35	8	LDF1-50A(1/4)	3.00 - 4.25	1.0000	1.0000
L35	10	CR 50 1070(7/8)	3.00 - 4.25	1.0000	1.0000
L35	11	FB-L98B-034-XXX(3/8)	3.00 - 4.25	1.0000	1.0000
L35	16	CU12PSM9P8XXX(1-3/8)	3.00 - 4.25	1.0000	1.0000
L35	18	MP3-06	3.00 - 4.25	1.0000	1.0000
L35	19	MP3-06	3.00 - 4.25	1.0000	1.0000
L35	20	MP3-06	3.00 - 4.25	1.0000	1.0000
L35	23	MP3-05	3.00 - 4.25	1.0000	1.0000
L35	24	MP3-05	3.00 - 4.25	1.0000	1.0000
L35	28	CCI-065125	3.00 - 4.25	1.0000	1.0000
L35	29	CCI-060100	4.00 - 4.25	1.0000	1.0000
L35	30	CCI-060100	4.00 - 4.25	1.0000	1.0000
L35	32	Stacked Plate	3.00 - 4.25	1.0000	1.0000
L35	33	Stacked Plate	3.00 - 4.25	1.0000	1.0000
L35	34	Stacked Plate	3.00 - 4.25	1.0000	1.0000
L36	5	MLE HYBRID 9POWER/18FIBER RL 2(1-5/8)	2.75 - 3.00	1.0000	1.0000
L36	6	FXL 780 PE(7/8)	2.75 - 3.00	1.0000	1.0000
L36	7	FXL 780 PE(7/8)	2.75 - 3.00	1.0000	1.0000
L36	8	LDF1-50A(1/4)	2.75 - 3.00	1.0000	1.0000
L36	10	CR 50 1070(7/8)	2.75 - 3.00	1.0000	1.0000
L36	11	FB-L98B-034-XXX(3/8)	2.75 - 3.00	1.0000	1.0000
L36	16	CU12PSM9P8XXX(1-3/8)	2.75 - 3.00	1.0000	1.0000

Tower Section	Feed Line Record No.	Description	Feed Line Segment Elev.	K _a No Ice	K _a Ice
L36	18	MP3-06	2.75 - 3.00	1.0000	1.0000
L36	19	MP3-06	2.75 - 3.00	1.0000	1.0000
L36	20	MP3-06	2.75 - 3.00	1.0000	1.0000
L36	23	MP3-05	2.75 - 3.00	1.0000	1.0000
L36	24	MP3-05	2.75 - 3.00	1.0000	1.0000
L36	28	CCI-065125	2.75 - 3.00	1.0000	1.0000
L36	32	Stacked Plate	2.75 - 3.00	1.0000	1.0000
L36	33	Stacked Plate	2.75 - 3.00	1.0000	1.0000
L36	34	Stacked Plate	2.75 - 3.00	1.0000	1.0000
L37	5	MLE HYBRID	1.75 - 2.75	1.0000	1.0000
		9POWER/18FIBER RL			
		2(1-5/8)			
L37	6	FXL 780 PE(7/8)	1.75 - 2.75	1.0000	1.0000
L37	7	FXL 780 PE(7/8)	1.75 - 2.75	1.0000	1.0000
L37	8	LDF1-50A(1/4)	1.75 - 2.75	1.0000	1.0000
L37	10	CR 50 1070(7/8)	1.75 - 2.75	1.0000	1.0000
L37	11	FB-L98B-034-XXX(3/8)	1.75 - 2.75	1.0000	1.0000
L37	16	CU12PSM9P8XXX(1-3/8)	1.75 - 2.75	1.0000	1.0000
L37	18	MP3-06	1.75 - 2.75	1.0000	1.0000
L37	19	MP3-06	1.75 - 2.75	1.0000	1.0000
L37	20	MP3-06	1.75 - 2.75	1.0000	1.0000
L37	23	MP3-05	2.25 - 2.75	1.0000	1.0000
L37	24	MP3-05	2.25 - 2.75	1.0000	1.0000
L37	28	CCI-065125	1.75 - 2.75	1.0000	1.0000
L37	32	Stacked Plate	1.75 - 2.75	1.0000	1.0000
L37	33	Stacked Plate	1.75 - 2.75	1.0000	1.0000
L37	34	Stacked Plate	1.75 - 2.75	1.0000	1.0000
L38	5	MLE HYBRID	1.50 - 1.75	1.0000	1.0000
		9POWER/18FIBER RL			
		2(1-5/8)			
L38	6	FXL 780 PE(7/8)	1.50 - 1.75	1.0000	1.0000
L38	7	FXL 780 PE(7/8)	1.50 - 1.75	1.0000	1.0000
L38	8	LDF1-50A(1/4)	1.50 - 1.75	1.0000	1.0000
L38	10	CR 50 1070(7/8)	1.50 - 1.75	1.0000	1.0000
L38	11	FB-L98B-034-XXX(3/8)	1.50 - 1.75	1.0000	1.0000
L38	16	CU12PSM9P8XXX(1-3/8)	1.50 - 1.75	1.0000	1.0000
L38	28	CCI-065125	1.50 - 1.75	1.0000	1.0000
L38	32	Stacked Plate	1.50 - 1.75	1.0000	1.0000
L38	33	Stacked Plate	1.50 - 1.75	1.0000	1.0000
L38	34	Stacked Plate	1.50 - 1.75	1.0000	1.0000
L39	5	MLE HYBRID	1.25 - 1.50	1.0000	1.0000
		9POWER/18FIBER RL			
		2(1-5/8)			
L39	6	FXL 780 PE(7/8)	1.25 - 1.50	1.0000	1.0000
L39	7	FXL 780 PE(7/8)	1.25 - 1.50	1.0000	1.0000
L39	8	LDF1-50A(1/4)	1.25 - 1.50	1.0000	1.0000
L39	10	CR 50 1070(7/8)	1.25 - 1.50	1.0000	1.0000
L39	11	FB-L98B-034-XXX(3/8)	1.25 - 1.50	1.0000	1.0000
L39	16	CU12PSM9P8XXX(1-3/8)	1.25 - 1.50	1.0000	1.0000
L39	28	CCI-065125	1.25 - 1.50	1.0000	1.0000
L40	5	MLE HYBRID	1.00 - 1.25	1.0000	1.0000
		9POWER/18FIBER RL			
		2(1-5/8)			
L40	6	FXL 780 PE(7/8)	1.00 - 1.25	1.0000	1.0000
L40	7	FXL 780 PE(7/8)	1.00 - 1.25	1.0000	1.0000
L40	8	LDF1-50A(1/4)	1.00 - 1.25	1.0000	1.0000
L40	10	CR 50 1070(7/8)	1.00 - 1.25	1.0000	1.0000
L40	11	FB-L98B-034-XXX(3/8)	1.00 - 1.25	1.0000	1.0000
L40	16	CU12PSM9P8XXX(1-3/8)	1.00 - 1.25	1.0000	1.0000
L40	28	CCI-065125	1.00 - 1.25	1.0000	1.0000
L41	5	MLE HYBRID	0.00 - 1.00	1.0000	1.0000
		9POWER/18FIBER RL			
		2(1-5/8)			
L41	6	FXL 780 PE(7/8)	0.00 - 1.00	1.0000	1.0000
L41	7	FXL 780 PE(7/8)	0.00 - 1.00	1.0000	1.0000
L41	8	LDF1-50A(1/4)	0.00 - 1.00	1.0000	1.0000
L41	10	CR 50 1070(7/8)	0.00 - 1.00	1.0000	1.0000
L41	11	FB-L98B-034-XXX(3/8)	0.00 - 1.00	1.0000	1.0000
L41	16	CU12PSM9P8XXX(1-3/8)	0.00 - 1.00	1.0000	1.0000

Tower Section	Feed Line Record No.	Description	Feed Line Segment Elev.	K _a No Ice	K _a Ice
L41	28	CCI-065125	0.50 - 1.00	1.0000	1.0000

Effective Width of Flat Linear Attachments / Feed Lines

Tower Section	Attachment Record No.	Description	Attachment Segment Elev.	Ratio Calculation Method	Effective Width Ratio
L3	25	MP3-05	85.50 - 88.00	Manual	1.0000
L3	26	MP3-05	85.50 - 88.00	Manual	1.0000
L3	27	MP3-05	85.50 - 88.00	Manual	1.0000
L4	25	MP3-05	85.25 - 85.50	Manual	1.0000
L4	26	MP3-05	85.25 - 85.50	Manual	1.0000
L4	27	MP3-05	85.25 - 85.50	Manual	1.0000
L5	25	MP3-05	80.25 - 85.25	Manual	1.0000
L5	26	MP3-05	80.25 - 85.25	Manual	1.0000
L5	27	MP3-05	80.25 - 85.25	Manual	1.0000
L5	35	5 x 1.25	80.25 - 81.50	Manual	1.0000
L5	36	5 x 1.25	80.25 - 81.50	Manual	1.0000
L5	37	5 x 1.25	80.25 - 81.50	Manual	1.0000
L6	25	MP3-05	75.25 - 80.25	Manual	1.0000
L6	26	MP3-05	75.25 - 80.25	Manual	1.0000
L6	27	MP3-05	75.25 - 80.25	Manual	1.0000
L6	35	5 x 1.25	75.25 - 80.25	Manual	1.0000
L6	36	5 x 1.25	75.25 - 80.25	Manual	1.0000
L6	37	5 x 1.25	75.25 - 80.25	Manual	1.0000
L7	25	MP3-05	70.25 - 75.25	Manual	1.0000
L7	26	MP3-05	70.25 - 75.25	Manual	1.0000
L7	27	MP3-05	70.25 - 75.25	Manual	1.0000
L7	32	Stacked Plate	70.25 - 71.50	Manual	1.0000
L7	33	Stacked Plate	70.25 - 71.50	Manual	1.0000
L7	34	Stacked Plate	70.25 - 71.50	Manual	1.0000
L7	35	5 x 1.25	71.50 - 75.25	Manual	1.0000
L7	36	5 x 1.25	71.50 - 75.25	Manual	1.0000

Tower Section	Attachment Record No.	Description	Attachment Segment Elev.	Ratio Calculation Method	Effective Width Ratio
L7	37	5 x 1.25	71.50 - 75.25	Manual	1.0000
L8	25	MP3-05	62.50 - 70.25	Manual	1.0000
L8	26	MP3-05	62.50 - 70.25	Manual	1.0000
L8	27	MP3-05	62.50 - 70.25	Manual	1.0000
L8	32	Stacked Plate	62.50 - 70.25	Manual	1.0000
L8	33	Stacked Plate	62.50 - 70.25	Manual	1.0000
L8	34	Stacked Plate	62.50 - 70.25	Manual	1.0000
L9	25	MP3-05	61.50 - 62.50	Manual	1.0000
L9	26	MP3-05	61.50 - 62.50	Manual	1.0000
L9	27	MP3-05	61.50 - 62.50	Manual	1.0000
L9	32	Stacked Plate	61.50 - 62.50	Manual	1.0000
L9	33	Stacked Plate	61.50 - 62.50	Manual	1.0000
L9	34	Stacked Plate	61.50 - 62.50	Manual	1.0000
L10	18	MP3-06	56.50 - 58.00	Manual	1.0000
L10	19	MP3-06	56.50 - 58.00	Manual	1.0000
L10	21	MP3-06	56.50 - 58.00	Manual	1.0000
L10	25	MP3-05	58.00 - 61.50	Manual	1.0000
L10	26	MP3-05	58.00 - 61.50	Manual	1.0000
L10	27	MP3-05	58.00 - 61.50	Manual	1.0000
L10	32	Stacked Plate	56.50 - 61.50	Manual	1.0000
L10	33	Stacked Plate	56.50 - 61.50	Manual	1.0000
L10	34	Stacked Plate	56.50 - 61.50	Manual	1.0000
L11	18	MP3-06	54.75 - 56.50	Manual	1.0000
L11	19	MP3-06	54.75 - 56.50	Manual	1.0000
L11	21	MP3-06	54.75 - 56.50	Manual	1.0000
L11	32	Stacked Plate	54.75 - 56.50	Manual	1.0000
L11	33	Stacked Plate	54.75 - 56.50	Manual	1.0000
L11	34	Stacked Plate	54.75 - 56.50	Manual	1.0000
L12	18	MP3-06	54.50 - 54.75	Manual	1.0000
L12	19	MP3-06	54.50 - 54.75	Manual	1.0000
L12	21	MP3-06	54.50 - 54.75	Manual	1.0000
L12	32	Stacked Plate	54.50 - 54.75	Manual	1.0000
L12	33	Stacked Plate	54.50 - 54.75	Manual	1.0000
L12	34	Stacked Plate	54.50 - 54.75	Manual	1.0000

Tower Section	Attachment Record No.	Description	Attachment Segment Elev.	Ratio Calculation Method	Effective Width Ratio
L13	18	MP3-06	49.50 - 54.50	Manual	1.0000
L13	19	MP3-06	49.50 - 54.50	Manual	1.0000
L13	21	MP3-06	49.50 - 54.50	Manual	1.0000
L13	32	Stacked Plate	49.50 - 54.50	Manual	1.0000
L13	33	Stacked Plate	49.50 - 54.50	Manual	1.0000
L13	34	Stacked Plate	49.50 - 54.50	Manual	1.0000
L14	18	MP3-06	44.50 - 49.50	Manual	1.0000
L14	19	MP3-06	44.50 - 49.50	Manual	1.0000
L14	21	MP3-06	44.50 - 49.50	Manual	1.0000
L14	32	Stacked Plate	44.50 - 49.50	Manual	1.0000
L14	33	Stacked Plate	44.50 - 49.50	Manual	1.0000
L14	34	Stacked Plate	44.50 - 49.50	Manual	1.0000
L15	18	MP3-06	39.50 - 44.50	Manual	1.0000
L15	19	MP3-06	39.50 - 44.50	Manual	1.0000
L15	21	MP3-06	39.50 - 44.50	Manual	1.0000
L15	32	Stacked Plate	39.50 - 44.50	Manual	1.0000
L15	33	Stacked Plate	39.50 - 44.50	Manual	1.0000
L15	34	Stacked Plate	39.50 - 44.50	Manual	1.0000
L16	18	MP3-06	34.50 - 39.50	Manual	1.0000
L16	19	MP3-06	34.50 - 39.50	Manual	1.0000
L16	21	MP3-06	34.50 - 39.50	Manual	1.0000
L16	22	MP3-05	34.50 - 35.00	Manual	1.0000
L16	32	Stacked Plate	34.50 - 39.50	Manual	1.0000
L16	33	Stacked Plate	34.50 - 39.50	Manual	1.0000
L16	34	Stacked Plate	34.50 - 39.50	Manual	1.0000
L17	18	MP3-06	29.00 - 34.50	Manual	1.0000
L17	19	MP3-06	29.00 - 34.50	Manual	1.0000
L17	21	MP3-06	29.00 - 34.50	Manual	1.0000
L17	22	MP3-05	29.00 - 34.50	Manual	1.0000
L17	23	MP3-05	29.00 - 32.00	Manual	1.0000
L17	24	MP3-05	29.00 - 32.00	Manual	1.0000
L17	32	Stacked Plate	29.00 - 34.50	Manual	1.0000
L17	33	Stacked Plate	29.00 - 34.50	Manual	1.0000
L17	34	Stacked Plate	29.00 - 34.50	Manual	1.0000

Tower Section	Attachment Record No.	Description	Attachment Segment Elev.	Ratio Calculation Method	Effective Width Ratio
L18	18	MP3-06	28.00 - 29.00	Manual	1.0000
L18	19	MP3-06	28.00 - 29.00	Manual	1.0000
L18	21	MP3-06	28.00 - 29.00	Manual	1.0000
L18	22	MP3-05	28.00 - 29.00	Manual	1.0000
L18	23	MP3-05	28.00 - 29.00	Manual	1.0000
L18	24	MP3-05	28.00 - 29.00	Manual	1.0000
L18	32	Stacked Plate	28.00 - 29.00	Manual	1.0000
L18	33	Stacked Plate	28.00 - 29.00	Manual	1.0000
L18	34	Stacked Plate	28.00 - 29.00	Manual	1.0000
L19	18	MP3-06	23.50 - 28.00	Manual	1.0000
L19	19	MP3-06	23.50 - 28.00	Manual	1.0000
L19	21	MP3-06	23.50 - 28.00	Manual	1.0000
L19	22	MP3-05	23.50 - 28.00	Manual	1.0000
L19	23	MP3-05	23.50 - 28.00	Manual	1.0000
L19	24	MP3-05	23.50 - 28.00	Manual	1.0000
L19	28	CCI-065125	23.50 - 25.50	Manual	1.0000
L19	29	CCI-060100	23.50 - 25.50	Manual	1.0000
L19	30	CCI-060100	23.50 - 25.50	Manual	1.0000
L19	32	Stacked Plate	23.50 - 28.00	Manual	1.0000
L19	33	Stacked Plate	23.50 - 28.00	Manual	1.0000
L19	34	Stacked Plate	23.50 - 28.00	Manual	1.0000
L20	18	MP3-06	23.25 - 23.50	Manual	1.0000
L20	19	MP3-06	23.25 - 23.50	Manual	1.0000
L20	21	MP3-06	23.25 - 23.50	Manual	1.0000
L20	22	MP3-05	23.25 - 23.50	Manual	1.0000
L20	23	MP3-05	23.25 - 23.50	Manual	1.0000
L20	24	MP3-05	23.25 - 23.50	Manual	1.0000
L20	28	CCI-065125	23.25 - 23.50	Manual	1.0000
L20	29	CCI-060100	23.25 - 23.50	Manual	1.0000
L20	30	CCI-060100	23.25 - 23.50	Manual	1.0000
L20	32	Stacked Plate	23.25 - 23.50	Manual	1.0000
L20	33	Stacked Plate	23.25 - 23.50	Manual	1.0000
L20	34	Stacked Plate	23.25 - 23.50	Manual	1.0000
L21	18	MP3-06	22.75 - 23.25	Manual	1.0000

Tower Section	Attachment Record No.	Description	Attachment Segment Elev.	Ratio Calculation Method	Effective Width Ratio
L21	19	MP3-06	22.75 - 23.25	Manual	1.0000
L21	21	MP3-06	22.75 - 23.25	Manual	1.0000
L21	22	MP3-05	22.75 - 23.25	Manual	1.0000
L21	23	MP3-05	22.75 - 23.25	Manual	1.0000
L21	24	MP3-05	22.75 - 23.25	Manual	1.0000
L21	28	CCI-065125	22.75 - 23.25	Manual	1.0000
L21	29	CCI-060100	22.75 - 23.25	Manual	1.0000
L21	30	CCI-060100	22.75 - 23.25	Manual	1.0000
L21	32	Stacked Plate	22.75 - 23.25	Manual	1.0000
L21	33	Stacked Plate	22.75 - 23.25	Manual	1.0000
L21	34	Stacked Plate	22.75 - 23.25	Manual	1.0000
L22	18	MP3-06	22.50 - 22.75	Manual	1.0000
L22	19	MP3-06	22.50 - 22.75	Manual	1.0000
L22	21	MP3-06	22.50 - 22.75	Manual	1.0000
L22	22	MP3-05	22.50 - 22.75	Manual	1.0000
L22	23	MP3-05	22.50 - 22.75	Manual	1.0000
L22	24	MP3-05	22.50 - 22.75	Manual	1.0000
L22	28	CCI-065125	22.50 - 22.75	Manual	1.0000
L22	29	CCI-060100	22.50 - 22.75	Manual	1.0000
L22	30	CCI-060100	22.50 - 22.75	Manual	1.0000
L22	32	Stacked Plate	22.50 - 22.75	Manual	1.0000
L22	33	Stacked Plate	22.50 - 22.75	Manual	1.0000
L22	34	Stacked Plate	22.50 - 22.75	Manual	1.0000
L23	18	MP3-06	17.50 - 22.50	Manual	1.0000
L23	19	MP3-06	17.50 - 22.50	Manual	1.0000
L23	20	MP3-06	17.50 - 19.00	Manual	1.0000
L23	21	MP3-06	17.50 - 22.50	Manual	1.0000
L23	22	MP3-05	17.50 - 22.50	Manual	1.0000
L23	23	MP3-05	17.50 - 22.50	Manual	1.0000
L23	24	MP3-05	17.50 - 22.50	Manual	1.0000
L23	28	CCI-065125	17.50 - 22.50	Manual	1.0000
L23	29	CCI-060100	17.50 - 22.50	Manual	1.0000
L23	30	CCI-060100	17.50 - 22.50	Manual	1.0000
L23	32	Stacked Plate	17.50 - 22.50	Manual	1.0000

Tower Section	Attachment Record No.	Description	Attachment Segment Elev.	Ratio Calculation Method	Effective Width Ratio
L23	33	Stacked Plate	17.50 - 22.50	Manual	1.0000
L23	34	Stacked Plate	17.50 - 22.50	Manual	1.0000
L24	18	MP3-06	15.75 - 17.50	Manual	1.0000
L24	19	MP3-06	15.75 - 17.50	Manual	1.0000
L24	20	MP3-06	15.75 - 17.50	Manual	1.0000
L24	21	MP3-06	15.75 - 17.50	Manual	1.0000
L24	22	MP3-05	15.75 - 17.50	Manual	1.0000
L24	23	MP3-05	15.75 - 17.50	Manual	1.0000
L24	24	MP3-05	15.75 - 17.50	Manual	1.0000
L24	28	CCI-065125	15.75 - 17.50	Manual	1.0000
L24	29	CCI-060100	15.75 - 17.50	Manual	1.0000
L24	30	CCI-060100	15.75 - 17.50	Manual	1.0000
L24	32	Stacked Plate	15.75 - 17.50	Manual	1.0000
L24	33	Stacked Plate	15.75 - 17.50	Manual	1.0000
L24	34	Stacked Plate	15.75 - 17.50	Manual	1.0000
L25	18	MP3-06	15.50 - 15.75	Manual	1.0000
L25	19	MP3-06	15.50 - 15.75	Manual	1.0000
L25	20	MP3-06	15.50 - 15.75	Manual	1.0000
L25	21	MP3-06	15.50 - 15.75	Manual	1.0000
L25	22	MP3-05	15.50 - 15.75	Manual	1.0000
L25	23	MP3-05	15.50 - 15.75	Manual	1.0000
L25	24	MP3-05	15.50 - 15.75	Manual	1.0000
L25	28	CCI-065125	15.50 - 15.75	Manual	1.0000
L25	29	CCI-060100	15.50 - 15.75	Manual	1.0000
L25	30	CCI-060100	15.50 - 15.75	Manual	1.0000
L25	32	Stacked Plate	15.50 - 15.75	Manual	1.0000
L25	33	Stacked Plate	15.50 - 15.75	Manual	1.0000
L25	34	Stacked Plate	15.50 - 15.75	Manual	1.0000
L26	18	MP3-06	12.25 - 15.50	Manual	1.0000
L26	19	MP3-06	12.25 - 15.50	Manual	1.0000
L26	20	MP3-06	12.25 - 15.50	Manual	1.0000
L26	21	MP3-06	12.25 - 15.50	Manual	1.0000
L26	22	MP3-05	12.25 - 15.50	Manual	1.0000
L26	23	MP3-05	12.25 - 15.50	Manual	1.0000

Tower Section	Attachment Record No.	Description	Attachment Segment Elev.	Ratio Calculation Method	Effective Width Ratio
L26	24	MP3-05	12.25 - 15.50	Manual	1.0000
L26	28	CCI-065125	12.25 - 15.50	Manual	1.0000
L26	29	CCI-060100	12.25 - 15.50	Manual	1.0000
L26	30	CCI-060100	12.25 - 15.50	Manual	1.0000
L26	32	Stacked Plate	12.25 - 15.50	Manual	1.0000
L26	33	Stacked Plate	12.25 - 15.50	Manual	1.0000
L26	34	Stacked Plate	12.25 - 15.50	Manual	1.0000
L27	18	MP3-06	12.00 - 12.25	Manual	1.0000
L27	19	MP3-06	12.00 - 12.25	Manual	1.0000
L27	20	MP3-06	12.00 - 12.25	Manual	1.0000
L27	21	MP3-06	12.00 - 12.25	Manual	1.0000
L27	22	MP3-05	12.00 - 12.25	Manual	1.0000
L27	23	MP3-05	12.00 - 12.25	Manual	1.0000
L27	24	MP3-05	12.00 - 12.25	Manual	1.0000
L27	28	CCI-065125	12.00 - 12.25	Manual	1.0000
L27	29	CCI-060100	12.00 - 12.25	Manual	1.0000
L27	30	CCI-060100	12.00 - 12.25	Manual	1.0000
L27	32	Stacked Plate	12.00 - 12.25	Manual	1.0000
L27	33	Stacked Plate	12.00 - 12.25	Manual	1.0000
L27	34	Stacked Plate	12.00 - 12.25	Manual	1.0000
L28	18	MP3-06	11.75 - 12.00	Manual	1.0000
L28	19	MP3-06	11.75 - 12.00	Manual	1.0000
L28	20	MP3-06	11.75 - 12.00	Manual	1.0000
L28	21	MP3-06	11.75 - 12.00	Manual	1.0000
L28	22	MP3-05	11.75 - 12.00	Manual	1.0000
L28	23	MP3-05	11.75 - 12.00	Manual	1.0000
L28	24	MP3-05	11.75 - 12.00	Manual	1.0000
L28	28	CCI-065125	11.75 - 12.00	Manual	1.0000
L28	29	CCI-060100	11.75 - 12.00	Manual	1.0000
L28	30	CCI-060100	11.75 - 12.00	Manual	1.0000
L28	32	Stacked Plate	11.75 - 12.00	Manual	1.0000
L28	33	Stacked Plate	11.75 - 12.00	Manual	1.0000
L28	34	Stacked Plate	11.75 - 12.00	Manual	1.0000
L29	18	MP3-06	11.50 - 11.75	Manual	1.0000

Tower Section	Attachment Record No.	Description	Attachment Segment Elev.	Ratio Calculation Method	Effective Width Ratio
L29	19	MP3-06	11.50 - 11.75	Manual	1.0000
L29	20	MP3-06	11.50 - 11.75	Manual	1.0000
L29	21	MP3-06	11.50 - 11.75	Manual	1.0000
L29	22	MP3-05	11.50 - 11.75	Manual	1.0000
L29	23	MP3-05	11.50 - 11.75	Manual	1.0000
L29	24	MP3-05	11.50 - 11.75	Manual	1.0000
L29	28	CCI-065125	11.50 - 11.75	Manual	1.0000
L29	29	CCI-060100	11.50 - 11.75	Manual	1.0000
L29	30	CCI-060100	11.50 - 11.75	Manual	1.0000
L29	32	Stacked Plate	11.50 - 11.75	Manual	1.0000
L29	33	Stacked Plate	11.50 - 11.75	Manual	1.0000
L29	34	Stacked Plate	11.50 - 11.75	Manual	1.0000
L30	18	MP3-06	6.50 - 11.50	Manual	1.0000
L30	19	MP3-06	6.50 - 11.50	Manual	1.0000
L30	20	MP3-06	6.50 - 11.50	Manual	1.0000
L30	21	MP3-06	8.50 - 11.50	Manual	1.0000
L30	22	MP3-05	10.00 - 11.50	Manual	1.0000
L30	23	MP3-05	6.50 - 11.50	Manual	1.0000
L30	24	MP3-05	6.50 - 11.50	Manual	1.0000
L30	28	CCI-065125	6.50 - 11.50	Manual	1.0000
L30	29	CCI-060100	6.50 - 11.50	Manual	1.0000
L30	30	CCI-060100	6.50 - 11.50	Manual	1.0000
L30	32	Stacked Plate	6.50 - 11.50	Manual	1.0000
L30	33	Stacked Plate	6.50 - 11.50	Manual	1.0000
L30	34	Stacked Plate	6.50 - 11.50	Manual	1.0000
L31	18	MP3-06	6.00 - 6.50	Manual	1.0000
L31	19	MP3-06	6.00 - 6.50	Manual	1.0000
L31	20	MP3-06	6.00 - 6.50	Manual	1.0000
L31	23	MP3-05	6.00 - 6.50	Manual	1.0000
L31	24	MP3-05	6.00 - 6.50	Manual	1.0000
L31	28	CCI-065125	6.00 - 6.50	Manual	1.0000
L31	29	CCI-060100	6.00 - 6.50	Manual	1.0000
L31	30	CCI-060100	6.00 - 6.50	Manual	1.0000
L31	32	Stacked Plate	6.00 - 6.50	Manual	1.0000
L31	33	Stacked Plate	6.00 - 6.50	Manual	1.0000
L31	34	Stacked Plate	6.00 - 6.50	Manual	1.0000
L32	18	MP3-06	5.75 - 6.00	Manual	1.0000
L32	19	MP3-06	5.75 - 6.00	Manual	1.0000
L32	20	MP3-06	5.75 - 6.00	Manual	1.0000
L32	23	MP3-05	5.75 - 6.00	Manual	1.0000
L32	24	MP3-05	5.75 - 6.00	Manual	1.0000
L32	28	CCI-065125	5.75 - 6.00	Manual	1.0000
L32	29	CCI-060100	5.75 - 6.00	Manual	1.0000
L32	30	CCI-060100	5.75 - 6.00	Manual	1.0000
L32	32	Stacked Plate	5.75 - 6.00	Manual	1.0000
L32	33	Stacked Plate	5.75 - 6.00	Manual	1.0000
L32	34	Stacked Plate	5.75 - 6.00	Manual	1.0000
L33	18	MP3-06	4.50 - 5.75	Manual	1.0000
L33	19	MP3-06	4.50 - 5.75	Manual	1.0000
L33	20	MP3-06	4.50 - 5.75	Manual	1.0000
L33	23	MP3-05	4.50 - 5.75	Manual	1.0000
L33	24	MP3-05	4.50 - 5.75	Manual	1.0000
L33	28	CCI-065125	4.50 - 5.75	Manual	1.0000
L33	29	CCI-060100	4.50 - 5.75	Manual	1.0000
L33	30	CCI-060100	4.50 - 5.75	Manual	1.0000

Tower Section	Attachment Record No.	Description	Attachment Segment Elev.	Ratio Calculation Method	Effective Width Ratio
L33	32	Stacked Plate	4.50 - 5.75	Manual	1.0000
L33	33	Stacked Plate	4.50 - 5.75	Manual	1.0000
L33	34	Stacked Plate	4.50 - 5.75	Manual	1.0000
L34	18	MP3-06	4.25 - 4.50	Manual	1.0000
L34	19	MP3-06	4.25 - 4.50	Manual	1.0000
L34	20	MP3-06	4.25 - 4.50	Manual	1.0000
L34	23	MP3-05	4.25 - 4.50	Manual	1.0000
L34	24	MP3-05	4.25 - 4.50	Manual	1.0000
L34	28	CCI-065125	4.25 - 4.50	Manual	1.0000
L34	29	CCI-060100	4.25 - 4.50	Manual	1.0000
L34	30	CCI-060100	4.25 - 4.50	Manual	1.0000
L34	32	Stacked Plate	4.25 - 4.50	Manual	1.0000
L34	33	Stacked Plate	4.25 - 4.50	Manual	1.0000
L34	34	Stacked Plate	4.25 - 4.50	Manual	1.0000
L35	18	MP3-06	3.00 - 4.25	Manual	1.0000
L35	19	MP3-06	3.00 - 4.25	Manual	1.0000
L35	20	MP3-06	3.00 - 4.25	Manual	1.0000
L35	23	MP3-05	3.00 - 4.25	Manual	1.0000
L35	24	MP3-05	3.00 - 4.25	Manual	1.0000
L35	28	CCI-065125	3.00 - 4.25	Manual	1.0000
L35	29	CCI-060100	4.00 - 4.25	Manual	1.0000
L35	30	CCI-060100	4.00 - 4.25	Manual	1.0000
L35	32	Stacked Plate	3.00 - 4.25	Manual	1.0000
L35	33	Stacked Plate	3.00 - 4.25	Manual	1.0000
L35	34	Stacked Plate	3.00 - 4.25	Manual	1.0000
L36	18	MP3-06	2.75 - 3.00	Manual	1.0000
L36	19	MP3-06	2.75 - 3.00	Manual	1.0000
L36	20	MP3-06	2.75 - 3.00	Manual	1.0000
L36	23	MP3-05	2.75 - 3.00	Manual	1.0000
L36	24	MP3-05	2.75 - 3.00	Manual	1.0000
L36	28	CCI-065125	2.75 - 3.00	Manual	1.0000
L36	32	Stacked Plate	2.75 - 3.00	Manual	1.0000
L36	33	Stacked Plate	2.75 - 3.00	Manual	1.0000
L36	34	Stacked Plate	2.75 - 3.00	Manual	1.0000
L37	18	MP3-06	1.75 - 2.75	Manual	1.0000
L37	19	MP3-06	1.75 - 2.75	Manual	1.0000
L37	20	MP3-06	1.75 - 2.75	Manual	1.0000
L37	23	MP3-05	2.25 - 2.75	Manual	1.0000
L37	24	MP3-05	2.25 - 2.75	Manual	1.0000
L37	28	CCI-065125	1.75 - 2.75	Manual	1.0000
L37	32	Stacked Plate	1.75 - 2.75	Manual	1.0000
L37	33	Stacked Plate	1.75 - 2.75	Manual	1.0000
L37	34	Stacked Plate	1.75 - 2.75	Manual	1.0000
L38	28	CCI-065125	1.50 - 1.75	Manual	1.0000
L38	32	Stacked Plate	1.50 - 1.75	Manual	1.0000
L38	33	Stacked Plate	1.50 - 1.75	Manual	1.0000
L38	34	Stacked Plate	1.50 - 1.75	Manual	1.0000
L39	28	CCI-065125	1.25 - 1.50	Manual	1.0000
L40	28	CCI-065125	1.00 - 1.25	Manual	1.0000
L41	28	CCI-065125	0.50 - 1.00	Manual	1.0000

Discrete Tower Loads

Description	Face or Leg	Offset Type	Offsets: Horz Lateral	Azimuth Adjustment	Placement	C _{AA} Front	C _{AA} Side	Weight
			ft ft ft	°	ft	ft ²	ft ²	K
8-ft Ladder	C	From Leg	2.0000 0.00	0.0000	99.0000	No Ice 7.0700 9.7300	7.0700 9.7300	0.04 0.07

Description	Face or Leg	Offset Type	Offsets: Horz Lateral Vert ft ft ft	Azimuth Adjustment t °	Placement ft	C _{AA} Front ft ²	C _{AA} Side ft ²	Weight K	
			1.00			1/2" Ice 13.9800	11.1900 11.1900	0.08 0.11	
Top Hat 15" Diameter x 4' Tall	C	None		0.0000	100.0000	1" Ice 2" Ice No Ice	2.5778 2.5778	0.20	
						1/2" Ice 4.1898	3.8792 4.1898	0.24 0.29	
						1" Ice 4.8389	4.8389	0.40	
***** ***									
X7C-680 w/ Mount Pipe	A	From Face	4.0000 -4.00 0.00	0.0000	102.0000	No Ice 1/2" Ice 1" Ice 2" Ice	7.2800 7.9500 8.6400 10.0700	5.9100 6.5700 7.2300 8.6200	0.07 0.13 0.21 0.40
X7C-680 w/ Mount Pipe	B	From Face	4.0000 -4.00 0.00	0.0000	102.0000	No Ice 1/2" Ice 1" Ice 2" Ice	7.2800 7.9500 8.6400 10.0700	5.9100 6.5700 7.2300 8.6200	0.07 0.13 0.21 0.40
X7C-680 w/ Mount Pipe	C	From Face	4.0000 -4.00 0.00	0.0000	102.0000	No Ice 1/2" Ice 1" Ice 2" Ice	7.2800 7.9500 8.6400 10.0700	5.9100 6.5700 7.2300 8.6200	0.07 0.13 0.21 0.40
(2) NHH-65B-R2B w/ Mount Pipe	A	From Face	4.0000 4.00 0.00	0.0000	102.0000	No Ice 1/2" Ice 1" Ice 2" Ice	4.0900 4.4800 4.8800 5.7000	3.2900 3.6700 4.0600 4.8600	0.07 0.13 0.21 0.39
(2) NHH-65B-R2B w/ Mount Pipe	B	From Face	4.0000 4.00 0.00	0.0000	102.0000	No Ice 1/2" Ice 1" Ice 2" Ice	4.0900 4.4800 4.8800 5.7000	3.2900 3.6700 4.0600 4.8600	0.07 0.13 0.21 0.39
(2) NHH-65B-R2B w/ Mount Pipe	C	From Face	4.0000 4.00 0.00	0.0000	102.0000	No Ice 1/2" Ice 1" Ice 2" Ice	4.0900 4.4800 4.8800 5.7000	3.2900 3.6700 4.0600 4.8600	0.07 0.13 0.21 0.39
MT6407-77A w/ Mount Pipe	A	From Face	4.0000 8.00 0.00	0.0000	102.0000	No Ice 1/2" Ice 1" Ice 2" Ice	4.9069 5.2559 5.6147 6.3615	2.6821 3.1450 3.6241 4.6310	0.10 0.14 0.18 0.29
MT6407-77A w/ Mount Pipe	B	From Face	4.0000 8.00 0.00	0.0000	102.0000	No Ice 1/2" Ice 1" Ice 2" Ice	4.9069 5.2559 5.6147 6.3615	2.6821 3.1450 3.6241 4.6310	0.10 0.14 0.18 0.29
MT6407-77A w/ Mount Pipe	C	From Face	4.0000 8.00 0.00	0.0000	102.0000	No Ice 1/2" Ice 1" Ice 2" Ice	4.9069 5.2559 5.6147 6.3615	2.6821 3.1450 3.6241 4.6310	0.10 0.14 0.18 0.29
RFV01U-D1A	A	From Face	4.0000 0.00 2.00	0.0000	102.0000	No Ice 1/2" Ice 1" Ice 2" Ice	1.8750 2.0454 2.2231 2.6009	1.2500 1.3926 1.5426 1.8648	0.08 0.10 0.12 0.18
RFV01U-D1A	B	From Face	4.0000 0.00 2.00	0.0000	102.0000	No Ice 1/2" Ice 1" Ice	1.8750 2.0454 2.2231	1.2500 1.3926 1.5426	0.08 0.10 0.12
						1" Ice	2.6009	1.8648	0.18

Description	Face or Leg	Offset Type	Offsets: Horz Lateral Vert ft ft ft	Azimuth Adjustment t °	Placement ft	C _{AA} Front ft ²	C _{AA} Side ft ²	Weight K
RFV01U-D1A	C	From Face	4.0000 0.00 2.00	0.0000	102.0000	2" Ice No Ice 1/2" Ice 1" Ice 2" Ice	1.8750 1.2500 2.0454 1.3926 2.2231 1.5426 2.6009 1.8648	0.08 0.10 0.12 0.18
RFV01U-D2A	A	From Centroid-Face	4.0000 0.00 2.00	0.0000	102.0000	2" Ice No Ice 1/2" Ice 1" Ice 2" Ice	1.8750 1.0125 2.0454 1.1445 2.2231 1.2840 2.6009 1.5851	0.07 0.09 0.11 0.15
RFV01U-D2A	B	From Face	4.0000 0.00 2.00	0.0000	102.0000	2" Ice No Ice 1/2" Ice 1" Ice 2" Ice	1.8750 1.0125 2.0454 1.1445 2.2231 1.2840 2.6009 1.5851	0.07 0.09 0.11 0.15
RFV01U-D2A	C	From Face	4.0000 0.00 2.00	0.0000	102.0000	2" Ice No Ice 1/2" Ice 1" Ice 2" Ice	1.8750 1.0125 2.0454 1.1445 2.2231 1.2840 2.6009 1.5851	0.07 0.09 0.11 0.15
RVZDC-6627-PF-48	A	From Face	4.0000 0.00 2.00	0.0000	102.0000	2" Ice No Ice 1/2" Ice 1" Ice 2" Ice	3.7922 2.5137 4.0441 2.7270 4.3033 2.9472 4.8439 3.4168	0.03 0.06 0.10 0.18
RVZDC-6627-PF-48	A	From Face	4.0000 0.00 2.00	0.0000	102.0000	2" Ice No Ice 1/2" Ice 1" Ice 2" Ice	3.7922 2.5137 4.0441 2.7270 4.3033 2.9472 4.8439 3.4168	0.03 0.06 0.10 0.18
12' Horizontal HSS 2" x 2" Tube	A	From Leg	4.0000 0.00 0.00	0.0000	102.0000	2" Ice No Ice 1/2" Ice 1" Ice 2" Ice	4.0000 0.0389 5.3580 0.0691 6.7284 0.0994 9.5062 0.1599	0.06 0.09 0.12 0.22
12' Horizontal HSS 2" x 2" Tube	B	From Leg	4.0000 0.00 0.00	0.0000	102.0000	2" Ice No Ice 1/2" Ice 1" Ice 2" Ice	4.0000 0.0389 5.3580 0.0691 6.7284 0.0994 9.5062 0.1599	0.06 0.09 0.12 0.22
12' Horizontal HSS 2" x 2" Tube	C	From Leg	4.0000 0.00 0.00	0.0000	102.0000	2" Ice No Ice 1/2" Ice 1" Ice 2" Ice	4.0000 0.0389 5.3580 0.0691 6.7284 0.0994 9.5062 0.1599	0.06 0.09 0.12 0.22
Side Arm Mount [SO 203-3]	C	None		0.0000	102.0000	2" Ice No Ice 1/2" Ice 1" Ice 2" Ice	6.6800 6.6800 8.0500 8.0500 9.5500 9.5500 12.8000 12.8000	0.38 0.46 0.57 0.87
Platform Mount (LP 101-1)	C	None		0.0000	102.0000	2" Ice No Ice 1/2" Ice 1" Ice 2" Ice	35.8300 35.8300 40.9800 40.9800 46.5700 46.5700 60.4600 60.4600	1.50 2.32 3.26 5.51

ERICSSON AIR 21 B4A B2P	A	From Face	4.0000 4.00 0.00	0.0000	94.0000	2" Ice No Ice 1/2" Ice 1" Ice 2" Ice	3.1900 1.9800 3.5200 2.2800 3.8500 2.5900 4.5500 3.2500	0.09 0.13 0.18 0.29
ERICSSON AIR 21 B2A B4P	A	From Face	4.0000 -4.00 0.00	0.0000	94.0000	2" Ice No Ice 1/2" Ice	3.1900 1.9800 3.5200 2.2800 3.8500 2.5900	0.09 0.13 0.18

Description	Face or Leg	Offset Type	Offsets:			Azimuth Adjustment	Placement	C _{AA} _{Front}	C _{AA} _{Side}	Weight
			Horz	Lateral	Vert					
			ft	ft	ft	°	ft	ft ²	ft ²	K
							1" Ice	4.5500	3.2500	0.29
							2" Ice			
ERICSSON AIR 21 B4A	B	From Face	4.0000	0.0000	94.0000		No Ice	3.1900	1.9800	0.09
B2P			4.00				1/2"	3.5200	2.2800	0.13
			0.00				Ice	3.8500	2.5900	0.18
							1" Ice	4.5500	3.2500	0.29
							2" Ice			
ERICSSON AIR 21 B2A	B	From Face	4.0000	0.0000	94.0000		No Ice	3.1900	1.9800	0.09
B4P			-4.00				1/2"	3.5200	2.2800	0.13
			0.00				Ice	3.8500	2.5900	0.18
							1" Ice	4.5500	3.2500	0.29
							2" Ice			
ERICSSON AIR 21 B4A	C	From Face	4.0000	0.0000	94.0000		No Ice	3.1900	1.9800	0.09
B2P			4.00				1/2"	3.5200	2.2800	0.13
			0.00				Ice	3.8500	2.5900	0.18
							1" Ice	4.5500	3.2500	0.29
							2" Ice			
ERICSSON AIR 21 B2A	C	From Face	4.0000	0.0000	94.0000		No Ice	3.1900	1.9800	0.09
B4P			-4.00				1/2"	3.5200	2.2800	0.13
			0.00				Ice	3.8500	2.5900	0.18
							1" Ice	4.5500	3.2500	0.29
							2" Ice			
T-Arm Mount [TA 702-3]	C	None		0.0000	94.0000		No Ice	4.7500	4.7500	0.34
							1/2"	5.8200	5.8200	0.43
							Ice	6.9800	6.9800	0.55
							1" Ice	9.7200	9.7200	0.87
							2" Ice			

80010965 w/ Mount Pipe	A	From Face	4.0000	0.0000	84.0000		No Ice	12.2600	5.7900	0.14
			-3.00				1/2"	13.0300	6.4700	0.23
			3.00				Ice	13.8000	7.1700	0.33
							1" Ice	15.4100	8.6000	0.57
							2" Ice			
80010965 w/ Mount Pipe	B	From Face	4.0000	0.0000	84.0000		No Ice	12.2600	5.7900	0.14
			-3.00				1/2"	13.0300	6.4700	0.23
			3.00				Ice	13.8000	7.1700	0.33
							1" Ice	15.4100	8.6000	0.57
							2" Ice			
80010965 w/ Mount Pipe	C	From Face	4.0000	0.0000	84.0000		No Ice	12.2600	5.7900	0.14
			-3.00				1/2"	13.0300	6.4700	0.23
			3.00				Ice	13.8000	7.1700	0.33
							1" Ice	15.4100	8.6000	0.57
							2" Ice			
DMP65R-BU6e w/ Mount Pipe	A	From Face	4.0000	0.0000	84.0000		No Ice	12.5200	7.4100	0.13
			-6.00				1/2"	13.2900	8.1200	0.22
			3.00				Ice	14.0900	8.8400	0.33
							1" Ice	15.7200	10.3300	0.57
							2" Ice			
DMP65R-BU6e w/ Mount Pipe	B	From Face	4.0000	0.0000	84.0000		No Ice	12.5200	7.4100	0.13
			-6.00				1/2"	13.2900	8.1200	0.22
			3.00				Ice	14.0900	8.8400	0.33
							1" Ice	15.7200	10.3300	0.57
							2" Ice			
DMP65R-BU6e w/ Mount Pipe	C	From Face	4.0000	0.0000	84.0000		No Ice	12.5200	7.4100	0.13
			-6.00				1/2"	13.2900	8.1200	0.22
			3.00				Ice	14.0900	8.8400	0.33
							1" Ice	15.7200	10.3300	0.57
							2" Ice			
AIR 6419 B77G w/ Mount Pipe	A	From Face	4.0000	0.0000	84.0000		No Ice	4.3200	2.4900	0.08
			7.00				1/2"	4.7400	2.8400	0.11
			2.00				Ice	5.1700	3.2100	0.15
							1" Ice	6.0900	4.0000	0.24
							2" Ice			
AIR 6419 B77G w/ Mount Pipe	B	From Face	4.0000	0.0000	84.0000		No Ice	4.3200	2.4900	0.08
			7.00					4.7400	2.8400	0.11

Description	Face or Leg	Offset Type	Offsets:			Azimuth Adjustment	Placement	C _{AA} _{Front}	C _{AA} _{Side}	Weight
			Horz	Lateral	Vert					
					2.00		1/2" Ice	5.1700	3.2100	0.15
							6.0900	4.0000	0.24	
							1" Ice			
							2" Ice			
AIR 6419 B77G w/ Mount Pipe	C	From Face	4.0000	0.0000	84.0000	No Ice	4.3200	2.4900	0.08	
			7.00			1/2"	4.7400	2.8400	0.11	
			2.00			Ice	5.1700	3.2100	0.15	
						1" Ice	6.0900	4.0000	0.24	
						2" Ice				
AIR 6449 N77 w/ Mount Pipe	A	From Face	4.0000	0.0000	84.0000	No Ice	3.6500	2.7200	0.11	
			5.00			1/2"	3.9900	3.0300	0.15	
			2.00			Ice	4.3500	3.3600	0.20	
						1" Ice	5.1100	4.0500	0.31	
						2" Ice				
AIR 6449 N77 w/ Mount Pipe	B	From Face	4.0000	0.0000	84.0000	No Ice	3.6500	2.7200	0.11	
			5.00			1/2"	3.9900	3.0300	0.15	
			2.00			Ice	4.3500	3.3600	0.20	
						1" Ice	5.1100	4.0500	0.31	
						2" Ice				
AIR 6449 N77 w/ Mount Pipe	C	From Face	4.0000	0.0000	84.0000	No Ice	3.6500	2.7200	0.11	
			5.00			1/2"	3.9900	3.0300	0.15	
			2.00			Ice	4.3500	3.3600	0.20	
						1" Ice	5.1100	4.0500	0.31	
						2" Ice				
RRUS 32 B2	A	From Face	4.0000	0.0000	84.0000	No Ice	2.7427	1.6681	0.05	
			0.00			1/2"	2.9647	1.8552	0.07	
			3.00			Ice	3.1941	2.0493	0.10	
						1" Ice	3.6753	2.4585	0.16	
						2" Ice				
RRUS 32 B2	B	From Face	4.0000	0.0000	84.0000	No Ice	2.7427	1.6681	0.05	
			0.00			1/2"	2.9647	1.8552	0.07	
			3.00			Ice	3.1941	2.0493	0.10	
						1" Ice	3.6753	2.4585	0.16	
						2" Ice				
RRUS 32 B2	C	From Face	4.0000	0.0000	84.0000	No Ice	2.7427	1.6681	0.05	
			0.00			1/2"	2.9647	1.8552	0.07	
			3.00			Ice	3.1941	2.0493	0.10	
						1" Ice	3.6753	2.4585	0.16	
						2" Ice				
RRUS 32 B66	A	From Face	4.0000	0.0000	84.0000	No Ice	2.7427	1.6681	0.05	
			0.00			1/2"	2.9647	1.8552	0.07	
			3.00			Ice	3.1941	2.0493	0.10	
						1" Ice	3.6753	2.4585	0.16	
						2" Ice				
RRUS 32 B66	B	From Face	4.0000	0.0000	84.0000	No Ice	2.7427	1.6681	0.05	
			0.00			1/2"	2.9647	1.8552	0.07	
			3.00			Ice	3.1941	2.0493	0.10	
						1" Ice	3.6753	2.4585	0.16	
						2" Ice				
RRUS 32 B66	C	From Face	4.0000	0.0000	84.0000	No Ice	2.7427	1.6681	0.05	
			0.00			1/2"	2.9647	1.8552	0.07	
			3.00			Ice	3.1941	2.0493	0.10	
						1" Ice	3.6753	2.4585	0.16	
						2" Ice				
RRUS 4478 B14	A	From Face	4.0000	0.0000	84.0000	No Ice	2.0212	1.2459	0.06	
			0.00			1/2"	2.1999	1.3960	0.08	
			3.00			Ice	2.3860	1.5536	0.10	
						1" Ice	2.7804	1.8909	0.15	
						2" Ice				
RRUS 4478 B14	B	From Face	4.0000	0.0000	84.0000	No Ice	2.0212	1.2459	0.06	
			0.00			1/2"	2.1999	1.3960	0.08	
			3.00			Ice	2.3860	1.5536	0.10	
						1" Ice	2.7804	1.8909	0.15	
						2" Ice				
RRUS 4478 B14	C	From Face	4.0000	0.0000	84.0000	No Ice	2.0212	1.2459	0.06	

Description	Face or Leg	Offset Type	Offsets: Horz Lateral Vert ft ft ft	Azimuth Adjustment t °	Placement ft	C _{AA} Front ft ²	C _{AA} Side ft ²	Weight K	
			0.00			1/2"	2.1999	1.3960	0.08
			3.00			Ice	2.3860	1.5536	0.10
						1" Ice	2.7804	1.8909	0.15
						2" Ice			
RRUS 32 B30	A	From Face	4.0000	0.0000	84.0000	No Ice	2.7427	1.6681	0.05
			0.00			1/2"	2.9647	1.8552	0.07
			3.00			Ice	3.1941	2.0493	0.10
						1" Ice	3.6753	2.4585	0.16
						2" Ice			
RRUS 32 B30	B	From Face	4.0000	0.0000	84.0000	No Ice	2.7427	1.6681	0.05
			0.00			1/2"	2.9647	1.8552	0.07
			3.00			Ice	3.1941	2.0493	0.10
						1" Ice	3.6753	2.4585	0.16
						2" Ice			
RRUS 32 B30	C	From Face	4.0000	0.0000	84.0000	No Ice	2.7427	1.6681	0.05
			0.00			1/2"	2.9647	1.8552	0.07
			3.00			Ice	3.1941	2.0493	0.10
						1" Ice	3.6753	2.4585	0.16
						2" Ice			
RRUS 4449 B5/B12	A	From Face	4.0000	0.0000	84.0000	No Ice	1.9675	1.4081	0.07
			0.00			1/2"	2.1439	1.5637	0.09
			3.00			Ice	2.3278	1.7267	0.11
						1" Ice	2.7177	2.0749	0.16
						2" Ice			
RRUS 4449 B5/B12	B	From Face	4.0000	0.0000	84.0000	No Ice	1.9675	1.4081	0.07
			0.00			1/2"	2.1439	1.5637	0.09
			3.00			Ice	2.3278	1.7267	0.11
						1" Ice	2.7177	2.0749	0.16
						2" Ice			
RRUS 4449 B5/B12	C	From Face	4.0000	0.0000	84.0000	No Ice	1.9675	1.4081	0.07
			0.00			1/2"	2.1439	1.5637	0.09
			3.00			Ice	2.3278	1.7267	0.11
						1" Ice	2.7177	2.0749	0.16
						2" Ice			
DC6-48-60-18-8F	A	From Face	4.0000	0.0000	84.0000	No Ice	1.2117	1.2117	0.03
			0.00			1/2"	1.8924	1.8924	0.05
			3.00			Ice	2.1051	2.1051	0.08
						1" Ice	2.5703	2.5703	0.14
						2" Ice			
DC6-48-60-18-8F	C	From Face	4.0000	0.0000	84.0000	No Ice	1.2117	1.2117	0.03
			0.00			1/2"	1.8924	1.8924	0.05
			3.00			Ice	2.1051	2.1051	0.08
						1" Ice	2.5703	2.5703	0.14
						2" Ice			
DC9-48-60-24-8C-EV	B	From Face	4.0000	0.0000	84.0000	No Ice	2.7366	4.7848	0.03
			0.00			1/2"	2.9630	5.0645	0.06
			3.00			Ice	3.1964	5.3517	0.10
						1" Ice	3.6842	5.9483	0.20
						2" Ice			
(2) T-Arm Mount [TA 602-3]	C	None		0.0000	84.0000	No Ice	13.4000	13.4000	0.77
						1/2"	16.4400	16.4400	1.00
						Ice	19.7000	19.7000	1.29
						1" Ice	25.8600	25.8600	2.05
						2" Ice			

MX08FRO665-21 w/ Mount Pipe	A	From Face	4.0000	0.0000	74.0000	No Ice	8.0100	4.2300	0.11
			0.00			1/2"	8.5200	4.6900	0.19
			0.00			Ice	9.0400	5.1600	0.29
						1" Ice	10.1100	6.1200	0.52
						2" Ice			
MX08FRO665-21 w/ Mount Pipe	B	From Face	4.0000	0.0000	74.0000	No Ice	8.0100	4.2300	0.11
			0.00			1/2"	8.5200	4.6900	0.19
			0.00			Ice	9.0400	5.1600	0.29
						1" Ice	10.1100	6.1200	0.52
						2" Ice			

Description	Face or Leg	Offset Type	Offsets:		Azimuth Adjustment	Placement		C _{AA}	C _{AA}	Weight
			Horz	Lateral				Front	Side	
			ft	ft	°	ft	ft ²	ft ²	K	
MX08FRO665-21 w/ Mount Pipe	C	From Face	4.0000	0.0000	0.0000	74.0000	No Ice	8.0100	4.2300	0.11
			0.00				1/2"	8.5200	4.6900	0.19
			0.00				Ice	9.0400	5.1600	0.29
							1" Ice	10.1100	6.1200	0.52
							2" Ice			
TA08025-B604	A	From Face	4.0000	0.0000	0.0000	74.0000	No Ice	1.9635	0.9811	0.06
			0.00				1/2"	2.1378	1.1117	0.08
			0.00				Ice	2.3195	1.2496	0.10
							1" Ice	2.7052	1.5477	0.15
							2" Ice			
TA08025-B605	A	From Face	4.0000	0.0000	0.0000	74.0000	No Ice	1.9635	1.1295	0.08
			0.00				1/2"	2.1378	1.2666	0.09
			0.00				Ice	2.3195	1.4112	0.11
							1" Ice	2.7052	1.7225	0.16
							2" Ice			
TA08025-B604	B	From Face	4.0000	0.0000	0.0000	74.0000	No Ice	1.9635	0.9811	0.06
			0.00				1/2"	2.1378	1.1117	0.08
			0.00				Ice	2.3195	1.2496	0.10
							1" Ice	2.7052	1.5477	0.15
							2" Ice			
TA08025-B605	B	From Face	4.0000	0.0000	0.0000	74.0000	No Ice	1.9635	1.1295	0.08
			0.00				1/2"	2.1378	1.2666	0.09
			0.00				Ice	2.3195	1.4112	0.11
							1" Ice	2.7052	1.7225	0.16
							2" Ice			
TA08025-B604	C	From Face	4.0000	0.0000	0.0000	74.0000	No Ice	1.9635	0.9811	0.06
			0.00				1/2"	2.1378	1.1117	0.08
			0.00				Ice	2.3195	1.2496	0.10
							1" Ice	2.7052	1.5477	0.15
							2" Ice			
TA08025-B605	C	From Face	4.0000	0.0000	0.0000	74.0000	No Ice	1.9635	1.1295	0.08
			0.00				1/2"	2.1378	1.2666	0.09
			0.00				Ice	2.3195	1.4112	0.11
							1" Ice	2.7052	1.7225	0.16
							2" Ice			
RDIDC-9181-PF-48	C	From Face	4.0000	0.0000	0.0000	74.0000	No Ice	2.0119	1.1682	0.02
			0.00				1/2"	2.1886	1.3109	0.04
			0.00				Ice	2.3727	1.4611	0.06
							1" Ice	2.7631	1.7837	0.11
							2" Ice			
2.375" OD x 6' Mount Pipe	A	From Face	4.0000	0.0000	0.0000	74.0000	No Ice	1.4250	1.4250	0.03
			4.00				1/2"	1.9250	1.9250	0.04
			0.00				Ice	2.2939	2.2939	0.05
							1" Ice	3.0596	3.0596	0.09
							2" Ice			
2.375" OD x 6' Mount Pipe	A	From Face	4.0000	0.0000	0.0000	74.0000	No Ice	1.4250	1.4250	0.03
			-4.00				1/2"	1.9250	1.9250	0.04
			0.00				Ice	2.2939	2.2939	0.05
							1" Ice	3.0596	3.0596	0.09
							2" Ice			
2.375" OD x 6' Mount Pipe	B	From Face	4.0000	0.0000	0.0000	74.0000	No Ice	1.4250	1.4250	0.03
			4.00				1/2"	1.9250	1.9250	0.04
			0.00				Ice	2.2939	2.2939	0.05
							1" Ice	3.0596	3.0596	0.09
							2" Ice			
2.375" OD x 6' Mount Pipe	B	From Face	4.0000	0.0000	0.0000	74.0000	No Ice	1.4250	1.4250	0.03
			-4.00				1/2"	1.9250	1.9250	0.04
			0.00				Ice	2.2939	2.2939	0.05
							1" Ice	3.0596	3.0596	0.09
							2" Ice			
2.375" OD x 6' Mount Pipe	C	From Face	4.0000	0.0000	0.0000	74.0000	No Ice	1.4250	1.4250	0.03
			4.00				1/2"	1.9250	1.9250	0.04
			0.00				Ice	2.2939	2.2939	0.05
							1" Ice	3.0596	3.0596	0.09
							2" Ice			

Description	Face or Leg	Offset Type	Offsets: Horz Lateral Vert ft ft ft	Azimuth Adjustment °	Placement ft		C _{AA} Front ft ²	C _{AA} Side ft ²	Weight K
2.375" OD x 6' Mount Pipe	C	From Face	4.0000	0.0000	74.0000	No Ice	1.4250	1.4250	0.03
			-4.00			1/2"	1.9250	1.9250	0.04
			0.00			Ice	2.2939	2.2939	0.05
						1" Ice	3.0596	3.0596	0.09
						2" Ice			
Commscope_MC-Pk8-DSH_Platform	C	None		0.0000	74.0000	No Ice	34.2400	34.2400	1.75
						1/2"	62.9500	62.9500	2.10
						Ice	91.6600	91.6600	2.45
						1" Ice	149.0800	149.0800	3.15
						2" Ice			

Tower Pressures - No Ice

$G_H = 1.100$

Section Elevation ft	z ft	K _Z	q _z psf	A _G ft ²	F a c e	A _F ft ²	A _R ft ²	A _{leg} ft ²	Leg %	C _{AA} In Face ft ²	C _{AA} Out Face ft ²
L1 100.0000-95.0000	97.4785	1.259	46.36	6.614	A	0.000	6.614	6.614	100.00	0.000	0.000
					B	0.000	6.614	100.00	0.000	0.000	
					C	0.000	6.614	100.00	0.000	0.000	
L2 95.0000-90.0000	92.4796	1.245	45.85	6.956	A	0.000	6.956	6.956	100.00	0.000	0.000
					B	0.000	6.956	100.00	4.054	0.000	
					C	0.000	6.956	100.00	0.000	0.000	
L3 90.0000-85.5000	87.7342	1.231	45.34	6.553	A	0.000	6.553	6.553	100.00	2.221	0.000
					B	0.000	6.553	100.00	6.782	0.000	
					C	0.000	6.553	100.00	2.221	0.000	
L4 85.5000-85.2500	85.3750	1.224	45.08	0.369	A	0.000	0.369	0.369	100.00	0.222	0.000
					B	0.000	0.369	100.00	0.475	0.000	
					C	0.000	0.369	100.00	0.222	0.000	
L5 85.2500-80.2500	82.7314	1.216	44.79	7.566	A	0.000	7.566	7.566	100.00	5.454	0.000
					B	0.000	7.566	100.00	11.533	0.000	
					C	0.000	7.566	100.00	4.442	0.000	
L6 80.2500-75.2500	77.7322	1.2	44.20	7.912	A	0.000	7.912	7.912	100.00	8.489	0.000
					B	0.000	7.912	100.00	17.604	0.000	
					C	0.000	7.912	100.00	4.442	0.000	
L7 75.2500-70.2500	72.7329	1.184	43.59	8.256	A	0.000	8.256	8.256	100.00	9.256	0.000
					B	0.000	8.256	100.00	18.080	0.000	
					C	0.000	8.256	100.00	4.442	0.000	
L8 70.2500-62.5000	66.3359	1.161	42.75	13.478	A	0.000	13.478	13.478	100.00	15.728	0.000
					B	0.000	13.478	100.00	30.239	0.000	
					C	0.000	13.478	100.00	6.885	0.000	
L9 62.5000-61.5000	61.9994	1.144	42.15	1.765	A	0.000	1.765	1.765	100.00	2.029	0.000
					B	0.000	1.765	100.00	3.902	0.000	
					C	0.000	1.765	100.00	0.888	0.000	
L10 61.5000-56.5000	58.9843	1.132	41.71	9.033	A	0.000	9.033	9.033	100.00	10.537	0.000
					B	0.000	9.033	100.00	19.899	0.000	
					C	0.000	9.033	100.00	4.832	0.000	
L11 56.5000-54.7500	55.6231	1.119	41.20	3.243	A	0.000	3.243	3.243	100.00	4.007	0.000
					B	0.000	3.243	100.00	7.283	0.000	
					C	0.000	3.243	100.00	2.010	0.000	
L12 54.7500-54.5000	54.6250	1.114	41.04	0.465	A	0.000	0.465	0.465	100.00	0.572	0.000
					B	0.000	0.465	100.00	1.040	0.000	
					C	0.000	0.465	100.00	0.287	0.000	
L13 54.5000-49.5000	51.9851	1.103	40.61	9.491	A	0.000	9.491	9.491	100.00	11.447	0.000
					B	0.000	9.491	100.00	20.809	0.000	
					C	0.000	9.491	100.00	5.742	0.000	

Section Elevation	z	K _z	q _z	A _G	F a c e	A _F	A _R	A _{leg}	Leg %	C _A A _A In Face ft ²	C _A A _A Out Face ft ²
ft	ft		psf	ft ²		ft ²	ft ²	ft ²		ft ²	ft ²
L14 49.5000- 44.5000	46.9856	1.08	39.76	9.837	A	0.000	9.837	9.837	100.00	11.447	0.000
					B	0.000	9.837		100.00	20.809	0.000
					C	0.000	9.837		100.00	5.742	0.000
L15 44.5000- 39.5000	41.9861	1.054	38.83	10.182	A	0.000	10.182	10.182	100.00	11.447	0.000
					B	0.000	10.182		100.00	20.809	0.000
					C	0.000	10.182		100.00	5.742	0.000
L16 39.5000- 34.5000	36.9866	1.027	37.81	10.528	A	0.000	10.528	10.528	100.00	11.891	0.000
					B	0.000	10.528		100.00	20.809	0.000
					C	0.000	10.528		100.00	5.742	0.000
L17 34.5000- 29.0000	31.7343	0.994	36.61	11.977	A	0.000	11.977	11.977	100.00	17.478	0.000
					B	0.000	11.977		100.00	25.555	0.000
					C	0.000	11.977		100.00	8.981	0.000
L18 29.0000- 28.0000	28.4995	0.972	35.79	2.171	A	0.000	2.171	2.171	100.00	3.178	0.000
					B	0.000	2.171		100.00	5.050	0.000
					C	0.000	2.171		100.00	2.037	0.000
L19 28.0000- 23.5000	25.7397	0.951	35.03	9.940	A	0.000	9.940	9.940	100.00	16.300	0.000
					B	0.000	9.940		100.00	26.892	0.000
					C	0.000	9.940		100.00	9.165	0.000
L20 23.5000- 23.2500	23.3750	0.932	34.32	0.560	A	0.000	0.560	0.560	100.00	1.044	0.000
					B	0.000	0.560		100.00	1.783	0.000
					C	0.000	0.560		100.00	0.509	0.000
L21 23.2500- 22.7500	22.9999	0.929	34.21	1.123	A	0.000	1.123	1.123	100.00	2.089	0.000
					B	0.000	1.123		100.00	3.567	0.000
					C	0.000	1.123		100.00	1.018	0.000
L22 22.7500- 22.5000	22.6250	0.926	34.09	0.562	A	0.000	0.562	0.562	100.00	1.044	0.000
					B	0.000	0.562		100.00	1.783	0.000
					C	0.000	0.562		100.00	0.509	0.000
L23 22.5000- 17.5000	19.9877	0.902	33.21	11.420	A	0.000	11.420	11.420	100.00	20.889	0.000
					B	0.000	11.420		100.00	35.667	0.000
					C	0.000	11.420		100.00	11.906	0.000
L24 17.5000- 15.7500	16.6235	0.867	31.95	4.079	A	0.000	4.079	4.079	100.00	7.311	0.000
					B	0.000	4.079		100.00	12.484	0.000
					C	0.000	4.079		100.00	5.574	0.000
L25 15.7500- 15.5000	15.6250	0.856	31.53	0.586	A	0.000	0.586	0.586	100.00	1.044	0.000
					B	0.000	0.586		100.00	1.783	0.000
					C	0.000	0.586		100.00	0.796	0.000
L26 15.5000- 12.2500	13.8700	0.85	31.30	7.692	A	0.000	7.692	7.692	100.00	13.578	0.000
					B	0.000	7.692		100.00	23.184	0.000
					C	0.000	7.692		100.00	10.351	0.000
L27 12.2500- 12.0000	12.1250	0.85	31.30	0.599	A	0.000	0.599	0.599	100.00	1.044	0.000
					B	0.000	0.599		100.00	1.783	0.000
					C	0.000	0.599		100.00	0.796	0.000
L28 12.0000- 11.7500	11.8750	0.85	31.30	0.599	A	0.000	0.599	0.599	100.00	1.044	0.000
					B	0.000	0.599		100.00	1.783	0.000
					C	0.000	0.599		100.00	0.796	0.000
L29 11.7500- 11.5000	11.6250	0.85	31.30	0.602	A	0.000	0.602	0.602	100.00	1.044	0.000
					B	0.000	0.602		100.00	1.783	0.000
					C	0.000	0.602		100.00	0.796	0.000
L30 11.5000- 6.5000	8.9884	0.85	31.30	12.216	A	0.000	12.216	12.216	100.00	17.780	0.000
					B	0.000	12.216		100.00	35.667	0.000
					C	0.000	12.216		100.00	13.628	0.000
L31 6.5000- 6.0000	6.2499	0.85	31.30	1.240	A	0.000	1.240	1.240	100.00	1.645	0.000
					B	0.000	1.240		100.00	3.567	0.000
					C	0.000	1.240		100.00	1.018	0.000
L32 6.0000- 5.7500	5.8750	0.85	31.30	0.621	A	0.000	0.621	0.621	100.00	0.822	0.000
					B	0.000	0.621		100.00	1.783	0.000
					C	0.000	0.621		100.00	0.509	0.000
L33 5.7500- 4.5000	5.1243	0.85	31.30	3.120	A	0.000	3.120	3.120	100.00	4.112	0.000
					B	0.000	3.120		100.00	8.917	0.000
					C	0.000	3.120		100.00	2.546	0.000
L34 4.5000- 4.2500	4.3750	0.85	31.30	0.626	A	0.000	0.626	0.626	100.00	0.822	0.000
					B	0.000	0.626		100.00	1.783	0.000
					C	0.000	0.626		100.00	0.509	0.000
L35 4.2500- 3.0000	3.6243	0.85	31.30	3.144	A	0.000	3.144	3.144	100.00	3.112	0.000
					B	0.000	3.144		100.00	7.917	0.000
					C	0.000	3.144		100.00	2.546	0.000
L36 3.0000- 2.7500	2.8750	0.85	31.30	0.631	A	0.000	0.631	0.631	100.00	0.572	0.000
					B	0.000	0.631		100.00	1.533	0.000

Section Elevation ft	z ft	K _Z	q _z psf	A _G ft ²	F a c e	A _F ft ²	A _R ft ²	A _{leg} ft ²	Leg %	C _A A _A In Face ft ²	C _A A _A Out Face ft ²
L37 2.7500-1.7500	2.2496	0.85	31.30	2.534	C	0.000	0.631	2.534	100.00	0.509	0.000
					A	0.000	2.534		100.00	2.289	0.000
					B	0.000	2.534		100.00	5.689	0.000
L38 1.7500-1.5000	1.6250	0.85	31.30	0.636	C	0.000	2.534	0.636	100.00	1.593	0.000
					A	0.000	0.636		100.00	0.285	0.000
					B	0.000	0.636		100.00	1.024	0.000
L39 1.5000-1.2500	1.3750	0.85	31.30	0.637	C	0.000	0.636	0.637	100.00	0.000	0.000
					A	0.000	0.637		100.00	0.035	0.000
					B	0.000	0.637		100.00	0.524	0.000
L40 1.2500-1.0000	1.1250	0.85	31.30	0.637	C	0.000	0.637	0.637	100.00	0.000	0.000
					A	0.000	0.637		100.00	0.035	0.000
					B	0.000	0.637		100.00	0.524	0.000
L41 1.0000-0.0000	0.4996	0.85	31.30	2.558	C	0.000	0.637	2.558	100.00	0.000	0.000
					A	0.000	2.558		100.00	0.141	0.000
					B	0.000	2.558		100.00	1.555	0.000
					C	0.000	2.558		100.00	0.000	0.000

Tower Pressure - With Ice

G_H = 1.100

Section Elevation ft	z ft	K _Z	q _z psf	t _z in	A _G ft ²	F a c e	A _F ft ²	A _R ft ²	A _{leg} ft ²	Leg %	C _A A _A In Face ft ²	C _A A _A Out Face ft ²
L1 100.0000-95.0000	97.4785	1.259	7.19	1.42	7.798	A	0.000	7.798	7.798	100.00	0.000	0.000
						B	0.000	7.798	100.00	0.000	0.000	
						C	0.000	7.798	100.00	0.000	0.000	
L2 95.0000-90.0000	92.4796	1.245	7.11	1.41	8.134	A	0.000	8.134	8.134	100.00	0.000	0.000
						B	0.000	8.134	100.00	10.404	0.000	
						C	0.000	8.134	100.00	0.000	0.000	
L3 90.0000-85.5000	87.7342	1.231	7.03	1.41	7.607	A	0.000	7.607	7.607	100.00	2.924	0.000
						B	0.000	7.607	100.00	14.596	0.000	
						C	0.000	7.607	100.00	2.924	0.000	
L4 85.5000-85.2500	85.3750	1.224	6.99	1.40	0.428	A	0.000	0.428	0.428	100.00	0.292	0.000
						B	0.000	0.428	100.00	0.940	0.000	
						C	0.000	0.428	100.00	0.292	0.000	
L5 85.2500-80.2500	82.7314	1.216	6.94	1.40	8.731	A	0.000	8.731	8.731	100.00	7.036	0.000
						B	0.000	8.731	100.00	22.474	0.000	
						C	0.000	8.731	100.00	6.888	0.000	
L6 80.2500-75.2500	77.7322	1.2	6.85	1.39	9.070	A	0.000	9.070	9.070	100.00	10.613	0.000
						B	0.000	9.070	100.00	30.021	0.000	
						C	0.000	9.070	100.00	7.220	0.000	
L7 75.2500-70.2500	72.7329	1.184	6.76	1.38	9.406	A	0.000	9.406	9.406	100.00	12.564	0.000
						B	0.000	9.406	100.00	30.748	0.000	
						C	0.000	9.406	100.00	7.201	0.000	
L8 70.2500-62.5000	66.3359	1.161	6.63	1.37	15.244	A	0.000	15.244	15.244	100.00	22.086	0.000
						B	0.000	15.244	100.00	51.209	0.000	
						C	0.000	15.244	100.00	11.123	0.000	
L9 62.5000-61.5000	61.9994	1.144	6.53	1.36	1.993	A	0.000	1.993	1.993	100.00	2.850	0.000
						B	0.000	1.993	100.00	6.608	0.000	
						C	0.000	1.993	100.00	1.435	0.000	
L10 61.5000-56.5000	58.9843	1.132	6.46	1.35	10.159	A	0.000	10.159	10.159	100.00	14.591	0.000
						B	0.000	10.159	100.00	33.284	0.000	
						C	0.000	10.159	100.00	7.534	0.000	
L11 56.5000-54.7500	55.6231	1.119	6.39	1.34	3.634	A	0.000	3.634	3.634	100.00	5.417	0.000
						B	0.000	3.634	100.00	11.943	0.000	
						C	0.000	3.634	100.00	2.950	0.000	
L12 54.7500-54.5000	54.6250	1.114	6.36	1.34	0.521	A	0.000	0.521	0.521	100.00	0.773	0.000
						B	0.000	0.521	100.00	1.705	0.000	
						C	0.000	0.521	100.00	0.421	0.000	
L13 54.5000-49.5000	51.9851	1.103	6.30	1.33	10.603	A	0.000	10.603	10.603	100.00	15.450	0.000
						B	0.000	10.603	100.00	34.041	0.000	
						C	0.000	10.603	100.00	8.410	0.000	

Section Elevation	z	K _z	q _z	t _z	A _G	F a c e	A _F	A _R	A _{leg}	Leg %	C _A A _A In Face ft ²	C _A A _A Out Face ft ²
ft	ft		psf	in	ft ²		ft ²	ft ²	ft ²		ft ²	ft ²
L14 49.5000- 44.5000	46.9856	1.08	6.16	1.32	10.938	A	0.000	10.938	10.938	100.00	15.410	0.000
						B	0.000	10.938		100.00	33.921	0.000
						C	0.000	10.938		100.00	8.383	0.000
L15 44.5000- 39.5000	41.9861	1.054	6.02	1.31	11.270	A	0.000	11.270	11.270	100.00	15.365	0.000
						B	0.000	11.270		100.00	33.788	0.000
						C	0.000	11.270		100.00	8.354	0.000
L16 39.5000- 34.5000	36.9866	1.027	5.86	1.29	11.603	A	0.000	11.603	11.603	100.00	15.889	0.000
						B	0.000	11.603		100.00	33.640	0.000
						C	0.000	11.603		100.00	8.321	0.000
L17 34.5000- 29.0000	31.7343	0.994	5.67	1.27	13.141	A	0.000	13.141	13.141	100.00	23.066	0.000
						B	0.000	13.141		100.00	40.236	0.000
						C	0.000	13.141		100.00	12.537	0.000
L18 29.0000- 28.0000	28.4995	0.972	5.55	1.26	2.382	A	0.000	2.382	2.382	100.00	4.194	0.000
						B	0.000	2.382		100.00	7.835	0.000
						C	0.000	2.382		100.00	2.799	0.000
L19 28.0000- 23.5000	25.7397	0.951	5.43	1.24	10.873	A	0.000	10.873	10.873	100.00	21.275	0.000
						B	0.000	10.873		100.00	40.182	0.000
						C	0.000	10.873		100.00	12.523	0.000
L20 23.5000- 23.2500	23.3750	0.932	5.32	1.23	0.612	A	0.000	0.612	0.612	100.00	1.352	0.000
						B	0.000	0.612		100.00	2.584	0.000
						C	0.000	0.612		100.00	0.694	0.000
L21 23.2500- 22.7500	22.9999	0.929	5.30	1.23	1.226	A	0.000	1.226	1.226	100.00	2.704	0.000
						B	0.000	1.226		100.00	5.165	0.000
						C	0.000	1.226		100.00	1.387	0.000
L22 22.7500- 22.5000	22.6250	0.926	5.28	1.23	0.613	A	0.000	0.613	0.613	100.00	1.351	0.000
						B	0.000	0.613		100.00	2.581	0.000
						C	0.000	0.613		100.00	0.693	0.000
L23 22.5000- 17.5000	19.9877	0.902	5.15	1.21	12.431	A	0.000	12.431	12.431	100.00	26.952	0.000
						B	0.000	12.431		100.00	51.443	0.000
						C	0.000	12.431		100.00	15.832	0.000
L24 17.5000- 15.7500	16.6235	0.867	4.95	1.19	4.427	A	0.000	4.427	4.427	100.00	9.394	0.000
						B	0.000	4.427		100.00	17.912	0.000
						C	0.000	4.427		100.00	7.156	0.000
L25 15.7500- 15.5000	15.6250	0.856	4.89	1.18	0.635	A	0.000	0.635	0.635	100.00	1.340	0.000
						B	0.000	0.635		100.00	2.554	0.000
						C	0.000	0.635		100.00	1.021	0.000
L26 15.5000- 12.2500	13.8700	0.85	4.85	1.17	8.326	A	0.000	8.326	8.326	100.00	17.377	0.000
						B	0.000	8.326		100.00	33.099	0.000
						C	0.000	8.326		100.00	13.241	0.000
L27 12.2500- 12.0000	12.1250	0.85	4.85	1.15	0.647	A	0.000	0.647	0.647	100.00	1.333	0.000
						B	0.000	0.647		100.00	2.537	0.000
						C	0.000	0.647		100.00	1.016	0.000
L28 12.0000- 11.7500	11.8750	0.85	4.85	1.15	0.647	A	0.000	0.647	0.647	100.00	1.332	0.000
						B	0.000	0.647		100.00	2.535	0.000
						C	0.000	0.647		100.00	1.015	0.000
L29 11.7500- 11.5000	11.6250	0.85	4.85	1.15	0.650	A	0.000	0.650	0.650	100.00	1.332	0.000
						B	0.000	0.650		100.00	2.534	0.000
						C	0.000	0.650		100.00	1.015	0.000
L30 11.5000- 6.5000	8.9884	0.85	4.85	1.12	13.149	A	0.000	13.149	13.149	100.00	22.594	0.000
						B	0.000	13.149		100.00	50.325	0.000
						C	0.000	13.149		100.00	17.451	0.000
L31 6.5000- 6.0000	6.2499	0.85	4.85	1.08	1.330	A	0.000	1.330	1.330	100.00	2.077	0.000
						B	0.000	1.330		100.00	4.985	0.000
						C	0.000	1.330		100.00	1.323	0.000
L32 6.0000- 5.7500	5.8750	0.85	4.85	1.07	0.666	A	0.000	0.666	0.666	100.00	1.037	0.000
						B	0.000	0.666		100.00	2.488	0.000
						C	0.000	0.666		100.00	0.661	0.000
L33 5.7500- 4.5000	5.1243	0.85	4.85	1.06	3.340	A	0.000	3.340	3.340	100.00	5.170	0.000
						B	0.000	3.340		100.00	12.398	0.000
						C	0.000	3.340		100.00	3.295	0.000
L34 4.5000- 4.2500	4.3750	0.85	4.85	1.04	0.670	A	0.000	0.670	0.670	100.00	1.031	0.000
						B	0.000	0.670		100.00	2.470	0.000
						C	0.000	0.670		100.00	0.657	0.000
L35 4.2500- 3.0000	3.6243	0.85	4.85	1.02	3.357	A	0.000	3.357	3.357	100.00	3.930	0.000
						B	0.000	3.357		100.00	11.085	0.000
						C	0.000	3.357		100.00	3.272	0.000
L36 3.0000- 2.7500	2.8750	0.85	4.85	1.00	0.673	A	0.000	0.673	0.673	100.00	0.722	0.000
						B	0.000	0.673		100.00	2.144	0.000

Section Elevation ft	z ft	K_z	q_z psf	t_z in	A_G ft ²	F a c e	A_F ft ²	A_R ft ²	A_{leg} ft ²	Leg %	$C_A A_A$ In Face ft ²	$C_A A_A$ Out Face ft ²
L37 2.7500- 1.7500	2.2496	0.85	4.85	0.97	2.696	C	0.000	0.673		100.00	0.651	0.000
						A	0.000	2.696	2.696	100.00	2.874	0.000
						B	0.000	2.696		100.00	7.981	0.000
						C	0.000	2.696		100.00	2.052	0.000
L38 1.7500- 1.5000	1.6250	0.85	4.85	0.94	0.675	A	0.000	0.675	0.675	100.00	0.380	0.000
						B	0.000	0.675		100.00	1.510	0.000
						C	0.000	0.675		100.00	0.047	0.000
L39 1.5000- 1.2500	1.3750	0.85	4.85	0.93	0.675	A	0.000	0.675	0.675	100.00	0.082	0.000
						B	0.000	0.675		100.00	0.910	0.000
						C	0.000	0.675		100.00	0.046	0.000
L40 1.2500- 1.0000	1.1250	0.85	4.85	0.91	0.675	A	0.000	0.675	0.675	100.00	0.081	0.000
						B	0.000	0.675		100.00	0.904	0.000
						C	0.000	0.675		100.00	0.045	0.000
L41 1.0000- 0.0000	0.4996	0.85	4.85	0.84	2.698	A	0.000	2.698	2.698	100.00	0.309	0.000
						B	0.000	2.698		100.00	2.890	0.000
						C	0.000	2.698		100.00	0.168	0.000

Tower Pressure - Service

$G_H = 1.100$

Section Elevation ft	z ft	K_z	q_z psf	A_G ft ²	F a c e	A_F ft ²	A_R ft ²	A_{leg} ft ²	Leg %	$C_A A_A$ In Face ft ²	$C_A A_A$ Out Face ft ²
L1 100.0000- 95.0000	97.4785	1.259	9.75	6.614	A	0.000	6.614	6.614	100.00	0.000	0.000
					B	0.000	6.614		100.00	0.000	0.000
					C	0.000	6.614		100.00	0.000	0.000
L2 95.0000- 90.0000	92.4796	1.245	9.64	6.956	A	0.000	6.956	6.956	100.00	0.000	0.000
					B	0.000	6.956		100.00	4.054	0.000
					C	0.000	6.956		100.00	0.000	0.000
L3 90.0000- 85.5000	87.7342	1.231	9.53	6.553	A	0.000	6.553	6.553	100.00	2.221	0.000
					B	0.000	6.553		100.00	6.782	0.000
					C	0.000	6.553		100.00	2.221	0.000
L4 85.5000- 85.2500	85.3750	1.224	9.48	0.369	A	0.000	0.369	0.369	100.00	0.222	0.000
					B	0.000	0.369		100.00	0.475	0.000
					C	0.000	0.369		100.00	0.222	0.000
L5 85.2500- 80.2500	82.7314	1.216	9.42	7.566	A	0.000	7.566	7.566	100.00	5.454	0.000
					B	0.000	7.566		100.00	11.533	0.000
					C	0.000	7.566		100.00	4.442	0.000
L6 80.2500- 75.2500	77.7322	1.2	9.29	7.912	A	0.000	7.912	7.912	100.00	8.489	0.000
					B	0.000	7.912		100.00	17.604	0.000
					C	0.000	7.912		100.00	4.442	0.000
L7 75.2500- 70.2500	72.7329	1.184	9.16	8.256	A	0.000	8.256	8.256	100.00	9.256	0.000
					B	0.000	8.256		100.00	18.080	0.000
					C	0.000	8.256		100.00	4.442	0.000
L8 70.2500- 62.5000	66.3359	1.161	8.99	13.478	A	0.000	13.478	13.478	100.00	15.728	0.000
					B	0.000	13.478		100.00	30.239	0.000
					C	0.000	13.478		100.00	6.885	0.000
L9 62.5000- 61.5000	61.9994	1.144	8.86	1.765	A	0.000	1.765	1.765	100.00	2.029	0.000
					B	0.000	1.765		100.00	3.902	0.000
					C	0.000	1.765		100.00	0.888	0.000
L10 61.5000- 56.5000	58.9843	1.132	8.77	9.033	A	0.000	9.033	9.033	100.00	10.537	0.000
					B	0.000	9.033		100.00	19.899	0.000
					C	0.000	9.033		100.00	4.832	0.000
L11 56.5000- 54.7500	55.6231	1.119	8.66	3.243	A	0.000	3.243	3.243	100.00	4.007	0.000
					B	0.000	3.243		100.00	7.283	0.000
					C	0.000	3.243		100.00	2.010	0.000
L12 54.7500- 54.5000	54.6250	1.114	8.63	0.465	A	0.000	0.465	0.465	100.00	0.572	0.000
					B	0.000	0.465		100.00	1.040	0.000
					C	0.000	0.465		100.00	0.287	0.000
L13 54.5000- 49.5000	51.9851	1.103	8.54	9.491	A	0.000	9.491	9.491	100.00	11.447	0.000
					B	0.000	9.491		100.00	20.809	0.000
					C	0.000	9.491		100.00	5.742	0.000

Section Elevation	z	K _z	q _z	A _G	F a c e	A _F	A _R	A _{leg}	Leg %	C _A A _A In Face ft ²	C _A A _A Out Face ft ²
ft	ft		psf	ft ²		ft ²	ft ²	ft ²		ft ²	ft ²
L14 49.5000- 44.5000	46.9856	1.08	8.36	9.837	A	0.000	9.837	9.837	100.00	11.447	0.000
					B	0.000	9.837		100.00	20.809	0.000
					C	0.000	9.837		100.00	5.742	0.000
L15 44.5000- 39.5000	41.9861	1.054	8.16	10.182	A	0.000	10.182	10.182	100.00	11.447	0.000
					B	0.000	10.182		100.00	20.809	0.000
					C	0.000	10.182		100.00	5.742	0.000
L16 39.5000- 34.5000	36.9866	1.027	7.95	10.528	A	0.000	10.528	10.528	100.00	11.891	0.000
					B	0.000	10.528		100.00	20.809	0.000
					C	0.000	10.528		100.00	5.742	0.000
L17 34.5000- 29.0000	31.7343	0.994	7.70	11.977	A	0.000	11.977	11.977	100.00	17.478	0.000
					B	0.000	11.977		100.00	25.555	0.000
					C	0.000	11.977		100.00	8.981	0.000
L18 29.0000- 28.0000	28.4995	0.972	7.52	2.171	A	0.000	2.171	2.171	100.00	3.178	0.000
					B	0.000	2.171		100.00	5.050	0.000
					C	0.000	2.171		100.00	2.037	0.000
L19 28.0000- 23.5000	25.7397	0.951	7.36	9.940	A	0.000	9.940	9.940	100.00	16.300	0.000
					B	0.000	9.940		100.00	26.892	0.000
					C	0.000	9.940		100.00	9.165	0.000
L20 23.5000- 23.2500	23.3750	0.932	7.22	0.560	A	0.000	0.560	0.560	100.00	1.044	0.000
					B	0.000	0.560		100.00	1.783	0.000
					C	0.000	0.560		100.00	0.509	0.000
L21 23.2500- 22.7500	22.9999	0.929	7.19	1.123	A	0.000	1.123	1.123	100.00	2.089	0.000
					B	0.000	1.123		100.00	3.567	0.000
					C	0.000	1.123		100.00	1.018	0.000
L22 22.7500- 22.5000	22.6250	0.926	7.17	0.562	A	0.000	0.562	0.562	100.00	1.044	0.000
					B	0.000	0.562		100.00	1.783	0.000
					C	0.000	0.562		100.00	0.509	0.000
L23 22.5000- 17.5000	19.9877	0.902	6.98	11.420	A	0.000	11.420	11.420	100.00	20.889	0.000
					B	0.000	11.420		100.00	35.667	0.000
					C	0.000	11.420		100.00	11.906	0.000
L24 17.5000- 15.7500	16.6235	0.867	6.72	4.079	A	0.000	4.079	4.079	100.00	7.311	0.000
					B	0.000	4.079		100.00	12.484	0.000
					C	0.000	4.079		100.00	5.574	0.000
L25 15.7500- 15.5000	15.6250	0.856	6.63	0.586	A	0.000	0.586	0.586	100.00	1.044	0.000
					B	0.000	0.586		100.00	1.783	0.000
					C	0.000	0.586		100.00	0.796	0.000
L26 15.5000- 12.2500	13.8700	0.85	6.58	7.692	A	0.000	7.692	7.692	100.00	13.578	0.000
					B	0.000	7.692		100.00	23.184	0.000
					C	0.000	7.692		100.00	10.351	0.000
L27 12.2500- 12.0000	12.1250	0.85	6.58	0.599	A	0.000	0.599	0.599	100.00	1.044	0.000
					B	0.000	0.599		100.00	1.783	0.000
					C	0.000	0.599		100.00	0.796	0.000
L28 12.0000- 11.7500	11.8750	0.85	6.58	0.599	A	0.000	0.599	0.599	100.00	1.044	0.000
					B	0.000	0.599		100.00	1.783	0.000
					C	0.000	0.599		100.00	0.796	0.000
L29 11.7500- 11.5000	11.6250	0.85	6.58	0.602	A	0.000	0.602	0.602	100.00	1.044	0.000
					B	0.000	0.602		100.00	1.783	0.000
					C	0.000	0.602		100.00	0.796	0.000
L30 11.5000- 6.5000	8.9884	0.85	6.58	12.216	A	0.000	12.216	12.216	100.00	17.780	0.000
					B	0.000	12.216		100.00	35.667	0.000
					C	0.000	12.216		100.00	13.628	0.000
L31 6.5000- 6.0000	6.2499	0.85	6.58	1.240	A	0.000	1.240	1.240	100.00	1.645	0.000
					B	0.000	1.240		100.00	3.567	0.000
					C	0.000	1.240		100.00	1.018	0.000
L32 6.0000- 5.7500	5.8750	0.85	6.58	0.621	A	0.000	0.621	0.621	100.00	0.822	0.000
					B	0.000	0.621		100.00	1.783	0.000
					C	0.000	0.621		100.00	0.509	0.000
L33 5.7500- 4.5000	5.1243	0.85	6.58	3.120	A	0.000	3.120	3.120	100.00	4.112	0.000
					B	0.000	3.120		100.00	8.917	0.000
					C	0.000	3.120		100.00	2.546	0.000
L34 4.5000- 4.2500	4.3750	0.85	6.58	0.626	A	0.000	0.626	0.626	100.00	0.822	0.000
					B	0.000	0.626		100.00	1.783	0.000
					C	0.000	0.626		100.00	0.509	0.000
L35 4.2500- 3.0000	3.6243	0.85	6.58	3.144	A	0.000	3.144	3.144	100.00	3.112	0.000
					B	0.000	3.144		100.00	7.917	0.000
					C	0.000	3.144		100.00	2.546	0.000
L36 3.0000- 2.7500	2.8750	0.85	6.58	0.631	A	0.000	0.631	0.631	100.00	0.572	0.000
					B	0.000	0.631		100.00	1.533	0.000

Section Elevation ft	z ft	K_z	q_z psf	A_G ft ²	F a c e	A_F ft ²	A_R ft ²	A_{leg} ft ²	Leg %	$C_A A_A$ In Face ft ²	$C_A A_A$ Out Face ft ²
L37 2.7500- 1.7500	2.2496	0.85	6.58	2.534	C	0.000	0.631	2.534	100.00	0.509	0.000
					A	0.000	2.534		100.00	2.289	0.000
					B	0.000	2.534		100.00	5.689	0.000
L38 1.7500- 1.5000	1.6250	0.85	6.58	0.636	C	0.000	2.534	0.636	100.00	1.593	0.000
					A	0.000	0.636		100.00	0.285	0.000
					B	0.000	0.636		100.00	1.024	0.000
L39 1.5000- 1.2500	1.3750	0.85	6.58	0.637	C	0.000	0.636	0.637	100.00	0.000	0.000
					A	0.000	0.637		100.00	0.035	0.000
					B	0.000	0.637		100.00	0.524	0.000
L40 1.2500- 1.0000	1.1250	0.85	6.58	0.637	C	0.000	0.637	0.637	100.00	0.000	0.000
					A	0.000	0.637		100.00	0.035	0.000
					B	0.000	0.637		100.00	0.524	0.000
L41 1.0000- 0.0000	0.4996	0.85	6.58	2.558	C	0.000	0.637	2.558	100.00	0.000	0.000
					A	0.000	2.558		100.00	0.141	0.000
					B	0.000	2.558		100.00	1.555	0.000
					C	0.000	2.558		100.00	0.000	0.000

Load Combinations

Comb. No.	Description
1	Dead Only
2	1.2 Dead+1.0 Wind 0 deg - No Ice
3	0.9 Dead+1.0 Wind 0 deg - No Ice
4	1.2 Dead+1.0 Wind 30 deg - No Ice
5	0.9 Dead+1.0 Wind 30 deg - No Ice
6	1.2 Dead+1.0 Wind 60 deg - No Ice
7	0.9 Dead+1.0 Wind 60 deg - No Ice
8	1.2 Dead+1.0 Wind 90 deg - No Ice
9	0.9 Dead+1.0 Wind 90 deg - No Ice
10	1.2 Dead+1.0 Wind 120 deg - No Ice
11	0.9 Dead+1.0 Wind 120 deg - No Ice
12	1.2 Dead+1.0 Wind 150 deg - No Ice
13	0.9 Dead+1.0 Wind 150 deg - No Ice
14	1.2 Dead+1.0 Wind 180 deg - No Ice
15	0.9 Dead+1.0 Wind 180 deg - No Ice
16	1.2 Dead+1.0 Wind 210 deg - No Ice
17	0.9 Dead+1.0 Wind 210 deg - No Ice
18	1.2 Dead+1.0 Wind 240 deg - No Ice
19	0.9 Dead+1.0 Wind 240 deg - No Ice
20	1.2 Dead+1.0 Wind 270 deg - No Ice
21	0.9 Dead+1.0 Wind 270 deg - No Ice
22	1.2 Dead+1.0 Wind 300 deg - No Ice
23	0.9 Dead+1.0 Wind 300 deg - No Ice
24	1.2 Dead+1.0 Wind 330 deg - No Ice
25	0.9 Dead+1.0 Wind 330 deg - No Ice
26	1.2 Dead+1.0 Ice+1.0 Temp
27	1.2 Dead+1.0 Wind 0 deg+1.0 Ice+1.0 Temp
28	1.2 Dead+1.0 Wind 30 deg+1.0 Ice+1.0 Temp
29	1.2 Dead+1.0 Wind 60 deg+1.0 Ice+1.0 Temp
30	1.2 Dead+1.0 Wind 90 deg+1.0 Ice+1.0 Temp
31	1.2 Dead+1.0 Wind 120 deg+1.0 Ice+1.0 Temp
32	1.2 Dead+1.0 Wind 150 deg+1.0 Ice+1.0 Temp
33	1.2 Dead+1.0 Wind 180 deg+1.0 Ice+1.0 Temp
34	1.2 Dead+1.0 Wind 210 deg+1.0 Ice+1.0 Temp
35	1.2 Dead+1.0 Wind 240 deg+1.0 Ice+1.0 Temp
36	1.2 Dead+1.0 Wind 270 deg+1.0 Ice+1.0 Temp
37	1.2 Dead+1.0 Wind 300 deg+1.0 Ice+1.0 Temp
38	1.2 Dead+1.0 Wind 330 deg+1.0 Ice+1.0 Temp
39	Dead+Wind 0 deg - Service
40	Dead+Wind 30 deg - Service
41	Dead+Wind 60 deg - Service
42	Dead+Wind 90 deg - Service
43	Dead+Wind 120 deg - Service
44	Dead+Wind 150 deg - Service

Comb. No.	Description
45	Dead+Wind 180 deg - Service
46	Dead+Wind 210 deg - Service
47	Dead+Wind 240 deg - Service
48	Dead+Wind 270 deg - Service
49	Dead+Wind 300 deg - Service
50	Dead+Wind 330 deg - Service

Maximum Member Forces

Section No.	Elevation ft	Component Type	Condition	Gov. Load Comb.	Axial K	Major Axis Moment kip-ft	Minor Axis Moment kip-ft
L1	100 - 95	Pole	Max Tension	26	0.00	-0.00	-0.00
			Max. Compression	26	-11.28	1.30	0.49
			Max. Mx	20	-3.84	50.26	0.60
			Max. My	2	-3.86	0.69	49.35
			Max. Vy	20	-7.39	50.26	0.60
			Max. Vx	14	7.32	-0.37	-49.20
			Max. Torque	2			1.88
L2	95 - 90	Pole	Max Tension	1	0.00	0.00	0.00
			Max. Compression	26	-13.99	1.23	0.54
			Max. Mx	20	-5.03	92.02	0.91
			Max. My	2	-5.07	1.00	90.71
			Max. Vy	20	-8.73	92.02	0.91
			Max. Vx	14	8.64	-0.67	-90.55
			Max. Torque	2			1.88
L3	90 - 85.5	Pole	Max Tension	1	0.00	0.00	0.00
			Max. Compression	26	-14.56	1.16	0.60
			Max. Mx	20	-5.28	132.15	1.20
			Max. My	14	-5.31	-0.95	-130.28
			Max. Vy	20	-9.12	132.15	1.20
			Max. Vx	14	9.03	-0.95	-130.28
			Max. Torque	2			1.88
L4	85.5 - 85.25	Pole	Max Tension	1	0.00	0.00	0.00
			Max. Compression	26	-14.61	1.15	0.61
			Max. Mx	20	-5.32	134.43	1.21
			Max. My	14	-5.34	-0.96	-132.54
			Max. Vy	20	-9.14	134.43	1.21
			Max. Vx	14	9.05	-0.96	-132.54
			Max. Torque	2			1.88
L5	85.25 - 80.25	Pole	Max Tension	1	0.00	0.00	0.00
			Max. Compression	26	-25.75	0.89	0.78
			Max. Mx	20	-9.90	217.69	1.74
			Max. My	14	-9.95	-1.46	-215.28
			Max. Vy	20	-16.04	217.69	1.74
			Max. Vx	14	15.85	-1.46	-215.28
			Max. Torque	2			1.88
L6	80.25 - 75.25	Pole	Max Tension	1	0.00	0.00	0.00
			Max. Compression	26	-27.04	0.77	0.88
			Max. Mx	20	-10.56	299.59	2.25
			Max. My	14	-10.63	-1.96	-295.87
			Max. Vy	20	-16.74	299.59	2.25
			Max. Vx	14	16.40	-1.96	-295.87
			Max. Torque	16			-1.34
L7	75.25 - 70.25	Pole	Max Tension	1	0.00	0.00	0.00
			Max. Compression	26	-34.00	0.66	0.61
			Max. Mx	20	-14.19	397.99	2.68
			Max. My	14	-14.27	-2.46	-392.40
			Max. Vy	20	-20.91	397.99	2.68
			Max. Vx	14	20.43	-2.46	-392.40
			Max. Torque	16			-1.34
L8	70.25 - 62.5	Pole	Max Tension	1	0.00	0.00	0.00
			Max. Compression	26	-35.04	0.57	0.72
			Max. Mx	20	-14.76	477.35	3.07

Section No.	Elevation ft	Component Type	Condition	Gov. Load Comb.	Axial K	Major Axis Moment kip-ft	Minor Axis Moment kip-ft
L9	62.5 - 61.5	Pole	Max. My	14	-14.84	-2.84	-469.92
			Max. Vy	20	-21.45	477.35	3.07
			Max. Vx	14	20.94	-2.84	-469.92
			Max. Torque	2			1.30
			Max Tension	1	0.00	0.00	0.00
			Max. Compression	26	-37.14	0.46	0.87
			Max. Mx	20	-16.04	586.56	3.58
			Max. My	14	-16.12	-3.34	-576.50
			Max. Vy	20	-22.25	586.56	3.58
			Max. Vx	14	21.70	-3.34	-576.50
L10	61.5 - 56.5	Pole	Max. Torque	2			1.30
			Max Tension	1	0.00	0.00	0.00
			Max. Compression	26	-38.62	0.35	1.02
			Max. Mx	20	-16.93	699.47	4.10
			Max. My	14	-17.01	-3.85	-686.60
			Max. Vy	20	-22.95	699.47	4.10
			Max. Vx	14	22.37	-3.85	-686.60
			Max. Torque	2			1.31
			Max Tension	1	0.00	0.00	0.00
			Max. Compression	26	-39.15	0.31	1.06
L11	56.5 - 54.75	Pole	Max. Mx	20	-17.24	739.81	4.28
			Max. My	14	-17.32	-4.02	-725.92
			Max. Vy	20	-23.20	739.81	4.28
			Max. Vx	14	22.61	-4.02	-725.92
			Max. Torque	2			1.31
			Max Tension	1	0.00	0.00	0.00
			Max. Compression	26	-39.24	0.30	1.07
			Max. Mx	20	-17.32	745.61	4.31
			Max. My	14	-17.40	-4.05	-731.57
			Max. Vy	20	-23.22	745.61	4.31
L12	54.75 - 54.5	Pole	Max. Vx	14	22.63	-4.05	-731.57
			Max. Torque	2			1.31
			Max Tension	1	0.00	0.00	0.00
			Max. Compression	26	-40.93	0.18	1.20
			Max. Mx	20	-18.39	863.48	4.82
			Max. My	14	-18.46	-4.55	-846.41
			Max. Vy	20	-23.95	863.48	4.82
			Max. Vx	14	23.34	-4.55	-846.41
			Max. Torque	2			1.31
			Max Tension	1	0.00	0.00	0.00
L13	54.5 - 49.5	Pole	Max. Compression	26	-42.63	0.06	1.34
			Max. Mx	20	-19.50	984.93	5.34
			Max. My	14	-19.56	-5.06	-964.71
			Max. Vy	20	-24.66	984.93	5.34
			Max. Vx	14	24.02	-5.06	-964.71
			Max. Torque	2			1.31
			Max Tension	1	0.00	0.00	0.00
			Max. Compression	26	-44.35	-0.06	1.48
			Max. Mx	20	-20.64	1109.84	5.85
			Max. My	14	-20.70	-5.56	-1086.35
L14	49.5 - 44.5	Pole	Max. Vy	20	-25.34	1109.84	5.85
			Max. Vx	14	24.68	-5.56	-1086.35
			Max. Torque	2			1.32
			Max Tension	1	0.00	0.00	0.00
			Max. Compression	26	-46.07	-0.18	1.63
			Max. Mx	20	-21.81	1238.10	6.36
			Max. My	14	-21.86	-6.07	-1211.22
			Max. Vy	20	-26.00	1238.10	6.36
			Max. Vx	14	25.32	-6.07	-1211.22
			Max. Torque	2			1.32
L15	44.5 - 39.5	Pole	Max Tension	1	0.00	0.00	0.00
			Max. Compression	26	-46.62	-0.21	1.68
			Max. Mx	20	-22.16	1277.21	6.51
			Max. My	14	-22.21	-6.22	-1249.32
			Max. Vy	20	-26.21	1277.21	6.51
			Max. Vx	14	25.52	-6.22	-1249.32
			Max. Torque	2			1.32
			Max Tension	1	0.00	0.00	0.00
			Max. Compression	26	-49.72	-0.33	1.84
			L16	39.5 - 34.5	Pole	Max. My	14
Max. Vy	20	-26.00				1238.10	6.36
Max. Vx	14	25.32				-6.07	-1211.22
Max. Torque	2						1.32
Max Tension	1	0.00				0.00	0.00
Max. Compression	26	-46.62				-0.21	1.68
Max. Mx	20	-22.16				1277.21	6.51
Max. My	14	-22.21				-6.22	-1249.32
Max. Vy	20	-26.21				1277.21	6.51
Max. Vx	14	25.52				-6.22	-1249.32
L17	34.5 - 29	Pole	Max. Torque	2			1.32
			Max Tension	1	0.00	0.00	0.00
			Max. Compression	26	-46.62	-0.21	1.68
			Max. Mx	20	-22.16	1277.21	6.51
			Max. My	14	-22.21	-6.22	-1249.32
			Max. Vy	20	-26.21	1277.21	6.51
			Max. Vx	14	25.52	-6.22	-1249.32
			Max. Torque	2			1.32
			Max Tension	1	0.00	0.00	0.00
			Max. Compression	26	-49.72	-0.33	1.84
L18	29 - 28	Pole	Max. My	14	-21.86	-6.07	-1211.22
			Max. Vy	20	-26.00	1238.10	6.36
			Max. Vx	14	25.32	-6.07	-1211.22

Section No.	Elevation ft	Component Type	Condition	Gov. Load Comb.	Axial K	Major Axis Moment kip-ft	Minor Axis Moment kip-ft
L19	28 - 23.5	Pole	Max. Mx	20	-24.36	1410.11	7.02
			Max. My	14	-24.41	-6.72	-1378.82
			Max. Vy	20	-26.98	1410.11	7.02
			Max. Vx	14	26.31	-6.72	-1378.82
			Max. Torque	2			1.33
			Max Tension	1	0.00	0.00	0.00
			Max. Compression	26	-51.76	-0.44	2.00
			Max. Mx	20	-25.73	1532.83	7.47
			Max. My	14	-25.77	-7.17	-1498.59
			Max. Vy	20	-27.60	1532.83	7.47
L20	23.5 - 23.25	Pole	Max. Vx	14	26.96	-7.17	-1498.59
			Max. Torque	2			1.33
			Max Tension	1	0.00	0.00	0.00
			Max. Compression	26	-51.89	-0.44	2.01
			Max. Mx	20	-25.83	1539.73	7.50
			Max. My	14	-25.87	-7.20	-1505.33
			Max. Vy	20	-27.63	1539.73	7.50
			Max. Vx	14	26.98	-7.20	-1505.33
			Max. Torque	2			1.33
			Max Tension	1	0.00	0.00	0.00
L21	23.25 - 22.75	Pole	Max. Compression	26	-52.15	-0.46	2.03
			Max. Mx	20	-26.01	1553.55	7.55
			Max. My	14	-26.04	-7.25	-1518.84
			Max. Vy	20	-27.70	1553.55	7.55
			Max. Vx	14	27.06	-7.25	-1518.84
			Max. Torque	2			1.33
			Max Tension	1	0.00	0.00	0.00
			Max. Compression	26	-52.29	-0.46	2.04
			Max. Mx	20	-26.11	1560.48	7.57
			Max. My	14	-26.14	-7.27	-1525.60
L22	22.75 - 22.5	Pole	Max. Vy	20	-27.73	1560.48	7.57
			Max. Vx	14	27.09	-7.27	-1525.60
			Max. Torque	2			1.33
			Max Tension	1	0.00	0.00	0.00
			Max. Compression	26	-55.05	-0.59	2.25
			Max. Mx	20	-28.03	1700.86	8.08
			Max. My	14	-28.06	-7.77	-1662.78
			Max. Vy	20	-28.45	1700.86	8.08
			Max. Vx	14	27.81	-7.77	-1662.78
			Max. Torque	2			1.35
L23	22.5 - 17.5	Pole	Max Tension	1	0.00	0.00	0.00
			Max. Compression	26	-56.03	-0.63	2.30
			Max. Mx	20	-28.70	1750.84	8.25
			Max. My	14	-28.73	-7.95	-1711.62
			Max. Vy	20	-28.72	1750.84	8.25
			Max. Vx	14	28.06	-7.95	-1711.62
			Max. Torque	2			1.35
			Max Tension	1	0.00	0.00	0.00
			Max. Compression	26	-56.18	-0.64	2.31
			Max. Mx	20	-28.83	1758.02	8.28
L24	17.5 - 15.75	Pole	Max. My	14	-28.86	-7.97	-1718.63
			Max. Vy	20	-28.73	1758.02	8.28
			Max. Vx	14	28.07	-7.97	-1718.63
			Max. Torque	2			1.35
			Max Tension	1	0.00	0.00	0.00
			Max. Compression	26	-58.10	-0.72	2.41
			Max. Mx	20	-30.20	1852.10	8.60
			Max. My	14	-30.22	-8.29	-1810.52
			Max. Vy	20	-29.20	1852.10	8.60
			Max. Vx	14	28.51	-8.29	-1810.52
L25	15.75 - 15.5	Pole	Max. Torque	2			1.36
			Max Tension	1	0.00	0.00	0.00
			Max. Compression	26	-58.24	-0.72	2.42
			Max. Mx	20	-30.31	1859.40	8.63
			Max. My	14	-30.34	-8.32	-1817.64
			Max. Vy	20	-29.22	1859.40	8.63
			Max. Vx	14	28.53	-8.32	-1817.64
			Max. Torque	2			1.36
			Max Tension	1	0.00	0.00	0.00
			Max. Compression	26	-58.24	-0.72	2.42
L26	15.5 - 12.25	Pole	Max. Mx	20	-30.20	1852.10	8.60
			Max. My	14	-30.22	-8.29	-1810.52
			Max. Vy	20	-29.20	1852.10	8.60
			Max. Vx	14	28.51	-8.29	-1810.52
			Max. Torque	2			1.36
			Max Tension	1	0.00	0.00	0.00
			Max. Compression	26	-58.24	-0.72	2.42
			Max. Mx	20	-30.31	1859.40	8.63
			Max. My	14	-30.34	-8.32	-1817.64
			Max. Vy	20	-29.22	1859.40	8.63
L27	12.25 - 12	Pole	Max. Vx	14	28.53	-8.32	-1817.64
			Max. Torque	2			1.36
			Max Tension	1	0.00	0.00	0.00
			Max. Compression	26	-58.24	-0.72	2.42
			Max. Mx	20	-30.31	1859.40	8.63
			Max. My	14	-30.34	-8.32	-1817.64
			Max. Vy	20	-29.22	1859.40	8.63
			Max. Vx	14	28.53	-8.32	-1817.64
			Max. Torque	2			1.36
			Max Tension	1	0.00	0.00	0.00

Section No.	Elevation ft	Component Type	Condition	Gov. Load Comb.	Axial K	Major Axis Moment kip-ft	Minor Axis Moment kip-ft
L28	12 - 11.75	Pole	Max Tension	1	0.00	0.00	0.00
			Max. Compression	26	-58.38	-0.73	2.42
			Max. Mx	20	-30.42	1866.71	8.65
			Max. My	14	-30.44	-8.34	-1824.78
			Max. Vy	20	-29.26	1866.71	8.65
			Max. Vx	14	28.56	-8.34	-1824.78
			Max. Torque	2			1.36
L29	11.75 - 11.5	Pole	Max Tension	1	0.00	0.00	0.00
			Max. Compression	26	-58.52	-0.73	2.43
			Max. Mx	20	-30.51	1874.02	8.68
			Max. My	14	-30.53	-8.37	-1831.92
			Max. Vy	20	-29.29	1874.02	8.68
			Max. Vx	14	28.60	-8.37	-1831.92
			Max. Torque	2			1.36
L30	11.5 - 6.5	Pole	Max Tension	1	0.00	0.00	0.00
			Max. Compression	26	-61.10	-0.87	2.57
			Max. Mx	20	-32.41	2021.98	9.17
			Max. My	14	-32.43	-8.87	-1976.32
			Max. Vy	20	-29.93	2021.98	9.17
			Max. Vx	14	29.20	-8.87	-1976.32
			Max. Torque	2			1.38
L31	6.5 - 6	Pole	Max Tension	1	0.00	0.00	0.00
			Max. Compression	26	-61.36	-0.88	2.59
			Max. Mx	20	-32.62	2036.95	9.22
			Max. My	14	-32.63	-8.92	-1990.92
			Max. Vy	20	-29.98	2036.95	9.22
			Max. Vx	14	29.25	-8.92	-1990.92
			Max. Torque	2			1.38
L32	6 - 5.75	Pole	Max Tension	1	0.00	0.00	0.00
			Max. Compression	26	-61.49	-0.88	2.60
			Max. Mx	20	-32.73	2044.44	9.25
			Max. My	14	-32.74	-8.94	-1998.23
			Max. Vy	20	-30.00	2044.44	9.25
			Max. Vx	14	29.27	-8.94	-1998.23
			Max. Torque	2			1.38
L33	5.75 - 4.5	Pole	Max Tension	1	0.00	0.00	0.00
			Max. Compression	26	-62.15	-0.91	2.64
			Max. Mx	20	-33.22	2082.03	9.37
			Max. My	14	-33.23	-9.06	-2034.90
			Max. Vy	20	-30.18	2082.03	9.37
			Max. Vx	14	29.44	-9.06	-2034.90
			Max. Torque	2			1.39
L34	4.5 - 4.25	Pole	Max Tension	1	0.00	0.00	0.00
			Max. Compression	26	-62.28	-0.92	2.65
			Max. Mx	20	-33.35	2089.57	9.40
			Max. My	14	-33.36	-9.09	-2042.26
			Max. Vy	20	-30.18	2089.57	9.40
			Max. Vx	14	29.45	-9.09	-2042.26
			Max. Torque	2			1.39
L35	4.25 - 3	Pole	Max Tension	1	0.00	0.00	0.00
			Max. Compression	26	-62.92	-0.95	2.69
			Max. Mx	20	-33.84	2127.37	9.52
			Max. My	14	-33.85	-9.21	-2079.14
			Max. Vy	20	-30.35	2127.37	9.52
			Max. Vx	14	29.61	-9.21	-2079.14
			Max. Torque	2			1.40
L36	3 - 2.75	Pole	Max Tension	1	0.00	0.00	0.00
			Max. Compression	26	-63.05	-0.96	2.69
			Max. Mx	20	-33.97	2134.96	9.54
			Max. My	14	-33.97	-9.24	-2086.54
			Max. Vy	20	-30.36	2134.96	9.54
			Max. Vx	14	29.62	-9.24	-2086.54
			Max. Torque	2			1.41
L37	2.75 - 1.75	Pole	Max Tension	1	0.00	0.00	0.00
			Max. Compression	26	-63.53	-0.98	2.73
			Max. Mx	20	-34.35	2165.36	9.64
			Max. My	14	-34.36	-9.33	-2116.20
			Max. Vy	20	-30.49	2165.36	9.64
			Max. Vx	14	29.74	-9.33	-2116.20

Section No.	Elevation ft	Component Type	Condition	Gov. Load Comb.	Axial K	Major Axis Moment kip-ft	Minor Axis Moment kip-ft
L38	1.75 - 1.5	Pole	Max. Torque	2			1.41
			Max Tension	1	0.00	0.00	0.00
			Max. Compression	26	-63.64	-0.99	2.74
			Max. Mx	20	-34.46	2172.98	9.67
			Max. My	14	-34.47	-9.36	-2123.64
			Max. Vy	20	-30.49	2172.98	9.67
			Max. Vx	14	29.74	-9.36	-2123.64
L39	1.5 - 1.25	Pole	Max. Torque	2			1.41
			Max Tension	1	0.00	0.00	0.00
			Max. Compression	26	-63.74	-0.99	2.74
			Max. Mx	20	-34.56	2180.60	9.69
			Max. My	14	-34.56	-9.38	-2131.07
			Max. Vy	20	-30.50	2180.60	9.69
			Max. Vx	14	29.76	-9.38	-2131.07
L40	1.25 - 1	Pole	Max. Torque	2			1.41
			Max Tension	1	0.00	0.00	0.00
			Max. Compression	26	-63.83	-1.00	2.75
			Max. Mx	20	-34.64	2188.22	9.72
			Max. My	14	-34.65	-9.41	-2138.51
			Max. Vy	20	-30.51	2188.22	9.72
			Max. Vx	14	29.77	-9.41	-2138.51
L41	1 - 0	Pole	Max. Torque	2			1.41
			Max Tension	1	0.00	0.00	0.00
			Max. Compression	26	-64.19	-1.02	2.77
			Max. Mx	20	-34.98	2218.73	9.81
			Max. My	14	-34.98	-9.51	-2168.29
			Max. Vy	20	-30.56	2218.73	9.81
			Max. Vx	14	29.83	-9.51	-2168.29
			Max. Torque	2			1.41

Maximum Reactions

Location	Condition	Gov. Load Comb.	Vertical K	Horizontal, X K	Horizontal, Z K
Pole	Max. Vert	37	64.19	6.23	3.61
	Max. H _x	20	35.00	30.54	0.09
	Max. H _z	2	35.00	0.09	29.58
	Max. M _x	2	2153.24	0.09	29.58
	Max. M _z	8	2188.87	-30.03	-0.09
	Max. Torsion	2	1.41	0.09	29.58
	Min. Vert	7	26.25	-23.73	13.65
	Min. H _x	9	26.25	-30.03	-0.09
	Min. H _z	14	35.00	-0.09	-29.81
	Min. M _x	14	-2168.29	-0.09	-29.81
	Min. M _z	20	-2218.73	30.54	0.09
	Min. Torsion	14	-1.38	-0.09	-29.81

Tower Mast Reaction Summary

Load Combination	Vertical K	Shear _x K	Shear _z K	Overturing Moment, M _x kip-ft	Overturing Moment, M _z kip-ft	Torque kip-ft
Dead Only	29.17	0.00	0.00	-0.28	-0.03	0.00
1.2 Dead+1.0 Wind 0 deg - No Ice	35.00	-0.09	-29.58	-2153.24	9.44	-1.41
0.9 Dead+1.0 Wind 0 deg - No Ice	26.25	-0.09	-29.58	-2129.32	9.32	-1.40
1.2 Dead+1.0 Wind 30 deg - No Ice	35.00	13.70	-23.84	-1806.04	-1037.28	-1.19

Load Combination	Vertical K	Shear _x K	Shear _z K	Overturning Moment, M _x kip-ft	Overturning Moment, M _z kip-ft	Torque kip-ft
0.9 Dead+1.0 Wind 30 deg - No Ice	26.25	13.70	-23.84	-1785.66	-1025.62	-1.18
1.2 Dead+1.0 Wind 60 deg - No Ice	35.00	23.73	-13.65	-1034.25	-1800.63	-0.77
0.9 Dead+1.0 Wind 60 deg - No Ice	26.25	23.73	-13.65	-1022.54	-1780.35	-0.77
1.2 Dead+1.0 Wind 90 deg - No Ice	35.00	30.03	0.09	9.13	-2188.87	-0.23
0.9 Dead+1.0 Wind 90 deg - No Ice	26.25	30.03	0.09	9.10	-2164.62	-0.23
1.2 Dead+1.0 Wind 120 deg - No Ice	35.00	26.72	15.49	1125.37	-1940.70	0.44
0.9 Dead+1.0 Wind 120 deg - No Ice	26.25	26.72	15.49	1113.03	-1919.27	0.43
1.2 Dead+1.0 Wind 150 deg - No Ice	35.00	14.21	24.53	1830.52	-1062.75	1.03
0.9 Dead+1.0 Wind 150 deg - No Ice	26.25	14.21	24.53	1810.11	-1050.83	1.02
1.2 Dead+1.0 Wind 180 deg - No Ice	35.00	0.09	29.81	2168.29	-9.51	1.38
0.9 Dead+1.0 Wind 180 deg - No Ice	26.25	0.09	29.81	2144.39	-9.38	1.37
1.2 Dead+1.0 Wind 210 deg - No Ice	35.00	-13.70	23.84	1800.36	1034.33	1.20
0.9 Dead+1.0 Wind 210 deg - No Ice	26.25	-13.70	23.84	1780.23	1022.72	1.19
1.2 Dead+1.0 Wind 240 deg - No Ice	35.00	-23.85	13.72	1034.91	1802.90	0.81
0.9 Dead+1.0 Wind 240 deg - No Ice	26.25	-23.85	13.72	1023.38	1782.64	0.81
1.2 Dead+1.0 Wind 270 deg - No Ice	35.00	-30.54	-0.09	-9.81	2218.73	0.26
0.9 Dead+1.0 Wind 270 deg - No Ice	26.25	-30.54	-0.09	-9.60	2194.23	0.26
1.2 Dead+1.0 Wind 300 deg - No Ice	35.00	-26.61	-15.43	-1124.37	1937.71	-0.45
0.9 Dead+1.0 Wind 300 deg - No Ice	26.25	-26.61	-15.43	-1111.85	1916.30	-0.44
1.2 Dead+1.0 Wind 330 deg - No Ice	35.00	-13.81	-23.84	-1793.60	1040.97	-1.07
0.9 Dead+1.0 Wind 330 deg - No Ice	26.25	-13.81	-23.84	-1773.33	1029.25	-1.07
1.2 Dead+1.0 Ice+1.0 Temp	64.19	0.00	-0.00	-2.77	-1.02	-0.00
1.2 Dead+1.0 Wind 0 deg+1.0 Ice+1.0 Temp	64.19	-0.02	-6.66	-527.47	0.64	-0.37
1.2 Dead+1.0 Wind 30 deg+1.0 Ice+1.0 Temp	64.19	3.02	-5.24	-437.56	-251.07	-0.32
1.2 Dead+1.0 Wind 60 deg+1.0 Ice+1.0 Temp	64.19	5.22	-3.01	-252.30	-434.79	-0.18
1.2 Dead+1.0 Wind 90 deg+1.0 Ice+1.0 Temp	64.19	7.04	0.02	-1.21	-548.58	-0.08
1.2 Dead+1.0 Wind 120 deg+1.0 Ice+1.0 Temp	64.19	6.25	3.62	277.60	-485.27	0.09
1.2 Dead+1.0 Wind 150 deg+1.0 Ice+1.0 Temp	64.19	3.15	5.44	437.45	-256.30	0.33
1.2 Dead+1.0 Wind 180 deg+1.0 Ice+1.0 Temp	64.19	0.02	6.68	523.20	-2.74	0.37
1.2 Dead+1.0 Wind 210 deg+1.0 Ice+1.0 Temp	64.19	-3.02	5.25	432.00	249.10	0.32
1.2 Dead+1.0 Wind 240 deg+1.0 Ice+1.0 Temp	64.19	-5.26	3.03	247.41	434.26	0.18
1.2 Dead+1.0 Wind 270 deg+1.0 Ice+1.0 Temp	64.19	-7.13	-0.02	-4.59	551.60	0.08
1.2 Dead+1.0 Wind 300 deg+1.0 Ice+1.0 Temp	64.19	-6.23	-3.61	-283.11	482.66	-0.09
1.2 Dead+1.0 Wind 330 deg+1.0 Ice+1.0 Temp	64.19	-3.09	-5.33	-437.59	250.93	-0.33
Dead+Wind 0 deg - Service	29.17	-0.02	-6.22	-450.56	1.96	-0.30
Dead+Wind 30 deg - Service	29.17	2.88	-5.01	-377.90	-216.93	-0.26

Load Combination	Vertical	Shear _x	Shear _z	Overturning Moment, M _x	Overturning Moment, M _z	Torque
	K	K	K	kip-ft	kip-ft	kip-ft
Dead+Wind 60 deg - Service	29.17	4.99	-2.87	-216.50	-376.56	-0.17
Dead+Wind 90 deg - Service	29.17	6.32	0.02	1.69	-457.83	-0.05
Dead+Wind 120 deg - Service	29.17	5.62	3.26	235.19	-405.96	0.10
Dead+Wind 150 deg - Service	29.17	2.99	5.16	382.62	-222.27	0.23
Dead+Wind 180 deg - Service	29.17	0.02	6.27	453.29	-1.99	0.30
Dead+Wind 210 deg - Service	29.17	-2.88	5.01	376.28	216.29	0.26
Dead+Wind 240 deg - Service	29.17	-5.02	2.89	216.21	377.02	0.17
Dead+Wind 270 deg - Service	29.17	-6.42	-0.02	-2.26	464.07	0.05
Dead+Wind 300 deg - Service	29.17	-5.60	-3.24	-235.40	405.31	-0.10
Dead+Wind 330 deg - Service	29.17	-2.90	-5.01	-375.30	217.68	-0.23

Solution Summary

Load Comb.	Sum of Applied Forces			Sum of Reactions			% Error
	PX K	PY K	PZ K	PX K	PY K	PZ K	
1	0.00	-29.17	0.00	0.00	29.17	0.00	0.000%
2	-0.09	-35.00	-29.58	0.09	35.00	29.58	0.000%
3	-0.09	-26.25	-29.58	0.09	26.25	29.58	0.000%
4	13.70	-35.00	-23.84	-13.70	35.00	23.84	0.000%
5	13.70	-26.25	-23.84	-13.70	26.25	23.84	0.000%
6	23.73	-35.00	-13.65	-23.73	35.00	13.65	0.000%
7	23.73	-26.25	-13.65	-23.73	26.25	13.65	0.000%
8	30.03	-35.00	0.09	-30.03	35.00	-0.09	0.000%
9	30.03	-26.25	0.09	-30.03	26.25	-0.09	0.000%
10	26.72	-35.00	15.49	-26.72	35.00	-15.49	0.000%
11	26.72	-26.25	15.49	-26.72	26.25	-15.49	0.000%
12	14.21	-35.00	24.53	-14.21	35.00	-24.53	0.000%
13	14.21	-26.25	24.53	-14.21	26.25	-24.53	0.000%
14	0.09	-35.00	29.81	-0.09	35.00	-29.81	0.000%
15	0.09	-26.25	29.81	-0.09	26.25	-29.81	0.000%
16	-13.70	-35.00	23.84	13.70	35.00	-23.84	0.000%
17	-13.70	-26.25	23.84	13.70	26.25	-23.84	0.000%
18	-23.85	-35.00	13.72	23.85	35.00	-13.72	0.000%
19	-23.85	-26.25	13.72	23.85	26.25	-13.72	0.000%
20	-30.54	-35.00	-0.09	30.54	35.00	0.09	0.000%
21	-30.54	-26.25	-0.09	30.54	26.25	0.09	0.000%
22	-26.61	-35.00	-15.43	26.61	35.00	15.43	0.000%
23	-26.61	-26.25	-15.43	26.61	26.25	15.43	0.000%
24	-13.81	-35.00	-23.84	13.81	35.00	23.84	0.000%
25	-13.81	-26.25	-23.84	13.81	26.25	23.84	0.000%
26	0.00	-64.19	0.00	-0.00	64.19	0.00	0.000%
27	-0.02	-64.19	-6.66	0.02	64.19	6.66	0.000%
28	3.02	-64.19	-5.24	-3.02	64.19	5.24	0.000%
29	5.22	-64.19	-3.01	-5.22	64.19	3.01	0.000%
30	7.04	-64.19	0.02	-7.04	64.19	-0.02	0.000%
31	6.25	-64.19	3.62	-6.25	64.19	-3.62	0.000%
32	3.15	-64.19	5.44	-3.15	64.19	-5.44	0.000%
33	0.02	-64.19	6.68	-0.02	64.19	-6.68	0.000%
34	-3.02	-64.19	5.25	3.02	64.19	-5.25	0.000%
35	-5.26	-64.19	3.03	5.26	64.19	-3.03	0.000%
36	-7.13	-64.19	-0.02	7.13	64.19	0.02	0.000%
37	-6.23	-64.19	-3.61	6.23	64.19	3.61	0.000%
38	-3.09	-64.19	-5.33	3.09	64.19	5.33	0.000%
39	-0.02	-29.17	-6.22	0.02	29.17	6.22	0.000%
40	2.88	-29.17	-5.01	-2.88	29.17	5.01	0.000%
41	4.99	-29.17	-2.87	-4.99	29.17	2.87	0.000%
42	6.32	-29.17	0.02	-6.32	29.17	-0.02	0.000%

Load Comb.	Sum of Applied Forces			Sum of Reactions			% Error
	PX K	PY K	PZ K	PX K	PY K	PZ K	
43	5.62	-29.17	3.26	-5.62	29.17	-3.26	0.000%
44	2.99	-29.17	5.16	-2.99	29.17	-5.16	0.000%
45	0.02	-29.17	6.27	-0.02	29.17	-6.27	0.000%
46	-2.88	-29.17	5.01	2.88	29.17	-5.01	0.000%
47	-5.02	-29.17	2.89	5.02	29.17	-2.89	0.000%
48	-6.42	-29.17	-0.02	6.42	29.17	0.02	0.000%
49	-5.60	-29.17	-3.24	5.60	29.17	3.24	0.000%
50	-2.90	-29.17	-5.01	2.90	29.17	5.01	0.000%

Non-Linear Convergence Results

Load Combination	Converged?	Number of Cycles	Displacement Tolerance	Force Tolerance
1	Yes	4	0.00000001	0.00000001
2	Yes	5	0.00000001	0.00077607
3	Yes	5	0.00000001	0.00034234
4	Yes	6	0.00000001	0.00050490
5	Yes	6	0.00000001	0.00015072
6	Yes	6	0.00000001	0.00053394
7	Yes	6	0.00000001	0.00016105
8	Yes	5	0.00000001	0.00007796
9	Yes	4	0.00000001	0.00073419
10	Yes	6	0.00000001	0.00056292
11	Yes	6	0.00000001	0.00016422
12	Yes	6	0.00000001	0.00051831
13	Yes	6	0.00000001	0.00015360
14	Yes	5	0.00000001	0.00048479
15	Yes	5	0.00000001	0.00021500
16	Yes	6	0.00000001	0.00053797
17	Yes	6	0.00000001	0.00016270
18	Yes	6	0.00000001	0.00050769
19	Yes	6	0.00000001	0.00015201
20	Yes	5	0.00000001	0.00029696
21	Yes	5	0.00000001	0.00012687
22	Yes	6	0.00000001	0.00055293
23	Yes	6	0.00000001	0.00016068
24	Yes	6	0.00000001	0.00053827
25	Yes	6	0.00000001	0.00016225
26	Yes	4	0.00000001	0.00018390
27	Yes	6	0.00000001	0.00052617
28	Yes	6	0.00000001	0.00061716
29	Yes	6	0.00000001	0.00062286
30	Yes	6	0.00000001	0.00053832
31	Yes	6	0.00000001	0.00068603
32	Yes	6	0.00000001	0.00061878
33	Yes	6	0.00000001	0.00052057
34	Yes	6	0.00000001	0.00061977
35	Yes	6	0.00000001	0.00061249
36	Yes	6	0.00000001	0.00054319
37	Yes	6	0.00000001	0.00069173
38	Yes	6	0.00000001	0.00063035
39	Yes	4	0.00000001	0.00082348
40	Yes	5	0.00000001	0.00012362
41	Yes	5	0.00000001	0.00014588
42	Yes	4	0.00000001	0.00035910
43	Yes	5	0.00000001	0.00016200
44	Yes	5	0.00000001	0.00013063
45	Yes	4	0.00000001	0.00076589
46	Yes	5	0.00000001	0.00015120
47	Yes	5	0.00000001	0.00012567
48	Yes	4	0.00000001	0.00039113
49	Yes	5	0.00000001	0.00015319
50	Yes	5	0.00000001	0.00014986

Maximum Tower Deflections - Service Wind

Section No.	Elevation ft	Horz. Deflection in	Gov. Load Comb.	Tilt °	Twist °
L1	100 - 95	16.2661	49	1.4754	0.0094
L2	95 - 90	14.7370	49	1.4398	0.0070
L3	90 - 85.5	13.2618	49	1.3732	0.0048
L4	85.5 - 85.25	12.0052	49	1.2906	0.0031
L5	85.25 - 80.25	11.9376	49	1.2888	0.0031
L6	80.25 - 75.25	10.6099	49	1.2447	0.0026
L7	75.25 - 70.25	9.3365	49	1.1857	0.0022
L8	70.25 - 62.5	8.1312	49	1.1147	0.0019
L9	66.5 - 61.5	7.2799	49	1.0524	0.0016
L10	61.5 - 56.5	6.2016	49	0.9989	0.0015
L11	56.5 - 54.75	5.2054	49	0.9028	0.0012
L12	54.75 - 54.5	4.8807	49	0.8687	0.0012
L13	54.5 - 49.5	4.8353	49	0.8647	0.0011
L14	49.5 - 44.5	3.9732	43	0.7820	0.0010
L15	44.5 - 39.5	3.2005	43	0.6940	0.0008
L16	39.5 - 34.5	2.5215	43	0.6028	0.0007
L17	34.5 - 29	1.9403	43	0.5071	0.0005
L18	33 - 28	1.7855	43	0.4783	0.0005
L19	28 - 23.5	1.3072	43	0.4297	0.0004
L20	23.5 - 23.25	0.9345	43	0.3611	0.0003
L21	23.25 - 22.75	0.9157	43	0.3573	0.0003
L22	22.75 - 22.5	0.8787	43	0.3497	0.0003
L23	22.5 - 17.5	0.8604	43	0.3464	0.0003
L24	17.5 - 15.75	0.5332	43	0.2787	0.0003
L25	15.75 - 15.5	0.4353	43	0.2550	0.0002
L26	15.5 - 12.25	0.4221	43	0.2518	0.0002
L27	12.25 - 12	0.2651	43	0.2095	0.0002
L28	12 - 11.75	0.2542	43	0.2059	0.0002
L29	11.75 - 11.5	0.2435	43	0.2024	0.0002
L30	11.5 - 6.5	0.2330	43	0.1979	0.0002
L31	6.5 - 6	0.0727	43	0.1084	0.0001
L32	6 - 5.75	0.0618	43	0.0995	0.0001
L33	5.75 - 4.5	0.0567	43	0.0951	0.0001
L34	4.5 - 4.25	0.0346	43	0.0735	0.0001
L35	4.25 - 3	0.0309	43	0.0694	0.0001
L36	3 - 2.75	0.0154	43	0.0490	0.0000
L37	2.75 - 1.75	0.0129	43	0.0449	0.0000
L38	1.75 - 1.5	0.0052	43	0.0287	0.0000
L39	1.5 - 1.25	0.0038	43	0.0245	0.0000
L40	1.25 - 1	0.0027	43	0.0203	0.0000
L41	1 - 0	0.0017	43	0.0162	0.0000

Critical Deflections and Radius of Curvature - Service Wind

Elevation ft	Appurtenance	Gov. Load Comb.	Deflection in	Tilt °	Twist °	Radius of Curvature ft
102.0000	X7C-680 w/ Mount Pipe	49	16.2661	1.4754	0.0094	5575
100.0000	Top Hat 15" Diameter x 4' Tall	49	16.2661	1.4754	0.0094	5575
99.0000	8-ft Ladder	49	15.9583	1.4691	0.0089	5575
94.0000	ERICSSON AIR 21 B4A B2P	49	14.4364	1.4304	0.0066	4871
84.0000	80010965 w/ Mount Pipe	49	11.6016	1.2798	0.0029	5105
74.0000	MX08FRO665-21 w/ Mount Pipe	49	9.0281	1.1697	0.0021	4143

Maximum Tower Deflections - Design Wind

Section No.	Elevation ft	Horz. Deflection in	Gov. Load Comb.	Tilt °	Twist °
L1	100 - 95	77.6105	22	7.0426	0.0443
L2	95 - 90	70.3389	22	6.8778	0.0332
L3	90 - 85.5	63.3215	10	6.5638	0.0227
L4	85.5 - 85.25	57.3385	10	6.1717	0.0144
L5	85.25 - 80.25	57.0168	10	6.1635	0.0143
L6	80.25 - 75.25	50.6893	10	5.9534	0.0121
L7	75.25 - 70.25	44.6178	10	5.6721	0.0103
L8	70.25 - 62.5	38.8674	10	5.3330	0.0087
L9	66.5 - 61.5	34.8041	10	5.0354	0.0076
L10	61.5 - 56.5	29.6556	10	4.7797	0.0069
L11	56.5 - 54.75	24.8971	10	4.3205	0.0057
L12	54.75 - 54.5	23.3457	10	4.1571	0.0053
L13	54.5 - 49.5	23.1288	10	4.1384	0.0053
L14	49.5 - 44.5	19.0066	10	3.7429	0.0045
L15	44.5 - 39.5	15.3105	10	3.3220	0.0037
L16	39.5 - 34.5	12.0624	10	2.8853	0.0030
L17	34.5 - 29	9.2821	10	2.4272	0.0024
L18	33 - 28	8.5415	10	2.2891	0.0022
L19	28 - 23.5	6.2530	10	2.0567	0.0019
L20	23.5 - 23.25	4.4701	10	1.7278	0.0016
L21	23.25 - 22.75	4.3802	10	1.7096	0.0015
L22	22.75 - 22.5	4.2031	10	1.6733	0.0015
L23	22.5 - 17.5	4.1159	10	1.6575	0.0015
L24	17.5 - 15.75	2.5503	10	1.3334	0.0012
L25	15.75 - 15.5	2.0823	10	1.2199	0.0010
L26	15.5 - 12.25	2.0189	10	1.2045	0.0010
L27	12.25 - 12	1.2679	10	1.0023	0.0008
L28	12 - 11.75	1.2159	10	0.9852	0.0008
L29	11.75 - 11.5	1.1648	10	0.9681	0.0008
L30	11.5 - 6.5	1.1146	10	0.9469	0.0008
L31	6.5 - 6	0.3477	10	0.5184	0.0004
L32	6 - 5.75	0.2956	10	0.4759	0.0004
L33	5.75 - 4.5	0.2712	10	0.4550	0.0004
L34	4.5 - 4.25	0.1656	10	0.3514	0.0003
L35	4.25 - 3	0.1478	10	0.3318	0.0003
L36	3 - 2.75	0.0736	10	0.2345	0.0002
L37	2.75 - 1.75	0.0618	10	0.2149	0.0002
L38	1.75 - 1.5	0.0249	10	0.1371	0.0001
L39	1.5 - 1.25	0.0183	10	0.1170	0.0001
L40	1.25 - 1	0.0127	10	0.0969	0.0001
L41	1 - 0	0.0081	10	0.0774	0.0001

Critical Deflections and Radius of Curvature - Design Wind

Elevation ft	Appurtenance	Gov. Load Comb.	Deflection in	Tilt °	Twist °	Radius of Curvature ft
102.0000	X7C-680 w/ Mount Pipe	22	77.6105	7.0426	0.0443	1229
100.0000	Top Hat 15" Diameter x 4' Tall	22	77.6105	7.0426	0.0443	1229
99.0000	8-ft Ladder	22	76.1474	7.0135	0.0420	1229
94.0000	ERICSSON AIR 21 B4A B2P	22	68.9086	6.8339	0.0312	1071
84.0000	80010965 w/ Mount Pipe	10	55.4155	6.1203	0.0137	1102
74.0000	MX08FRO665-21 w/ Mount Pipe	10	43.1467	5.5956	0.0099	887

Compression Checks

Pole Design Data

Section No.	Elevation ft	Size	L ft	L_u ft	Kl/r	A in^2	P_u K
L1	100 - 99	TP15.79x15x0.19	5.0000	0.0000	0.0	9.16	-3.66
	99 - 98					9.25	-3.70
	98 - 97					9.35	-3.74
	97 - 96					9.45	-3.78
	96 - 95					9.55	-3.82
L2	95 - 94	TP16.59x15.79x0.19	5.0000	0.0000	0.0	9.64	-3.87
	94 - 93					9.74	-4.87
	93 - 92					9.84	-4.91
	92 - 91					9.93	-4.96
	91 - 90					10.03	-5.02
L3	90 - 88.875	TP17.3x16.59x0.19	4.5000	0.0000	0.0	10.14	-5.07
	88.875 - 87.75					10.25	-5.13
	87.75 - 86.625					10.36	-5.19
L4	86.625 - 85.5	TP17.34x17.3x0.6	0.2500	0.0000	0.0	10.47	-5.25
	85.5 - 85.25 (4)					32.47	-5.29
L5	85.25 - 84.25	TP18.13x17.34x0.58	5.0000	0.0000	0.0	31.47	-5.40
	84.25 - 83.25					31.76	-9.48
	83.25 - 82.25					32.06	-9.60
	82.25 - 81.25					32.35	-9.73
	81.25 - 80.25					32.65	-9.86
L6	80.25 - 79.25	TP18.93x18.13x0.55	5.0000	0.0000	0.0	31.56	-9.99
	79.25 - 78.25					31.84	-10.12
	78.25 - 77.25					32.12	-10.25
	77.25 - 76.25					32.41	-10.38
	76.25 - 75.25					32.69	-10.52
L7	75.25 - 74.25	TP19.72x18.93x0.54	5.0000	0.0000	0.0	32.25	-10.66
	74.25 - 73.25					32.52	-13.70
	73.25 - 72.25					32.80	-13.85
	72.25 - 71.25					33.07	-13.99
	71.25 - 70.25					33.35	-14.14
L8	70.25 - 69	TP20.95x19.72x0.52	7.7500	0.0000	0.0	32.56	-14.33
	69 - 67.75					32.89	-14.52
	67.75 - 66.5					33.22	-14.71
	66.5 - 62.5					34.29	-7.60
L9	66.5 - 62.5	TP20.73x19.94x0.58	5.0000	0.0000	0.0	37.03	-8.20
	62.5 - 61.5					37.33	-16.00
L10	61.5 - 60.5	TP21.53x20.73x0.56	5.0000	0.0000	0.0	36.82	-16.17
	60.5 - 59.5					37.11	-16.35
	59.5 - 58.5					37.40	-16.53
	58.5 - 57.5					37.69	-16.72
L11	57.5 - 56.5	TP21.81x21.53x0.56	1.7500	0.0000	0.0	37.98	-16.90
	56.5 - 54.75 (11)					38.48	-17.21
L12	54.75 - 54.5 (12)	TP21.85x21.81x0.74	0.2500	0.0000	0.0	50.13	-17.29
L13	54.5 - 53.5	TP22.64x21.85x0.71	5.0000	0.0000	0.0	48.85	-17.49
	53.5 - 52.5					49.22	-17.70
	52.5 - 51.5					49.58	-17.92
	51.5 - 50.5					49.95	-18.14
	50.5 - 49.5					50.31	-18.36
L14	49.5 - 48.5	TP23.44x22.64x0.69	5.0000	0.0000	0.0	48.95	-18.58
	48.5 - 47.5					49.31	-18.80
	47.5 - 46.5					49.66	-19.02
	46.5 - 45.5					50.01	-19.24
	45.5 - 44.5					50.36	-19.47
L15	44.5 - 43.5	TP24.23x23.44x0.68	5.0000	0.0000	0.0	49.82	-19.69
	43.5 - 42.5					50.16	-19.92
	42.5 - 41.5					50.51	-20.15
	41.5 - 40.5					50.85	-20.38
	40.5 - 39.5					51.20	-20.61
L16	39.5 - 38.5	TP25.03x24.23x0.65	5.0000	0.0000	0.0	49.69	-20.85
	38.5 - 37.5					50.02	-21.08
	37.5 - 36.5					50.35	-21.32
	36.5 - 35.5					50.69	-21.55
	35.5 - 34.5					51.02	-21.79
L17	34.5 - 33	TP25.9x25.03x0.65	5.5000	0.0000	0.0	51.52	-22.14

Section No.	Elevation ft	Size	L ft	L_u ft	Kl/r	A in^2	P_u K
L18	33 - 29	TP25.55x24.76x0.93	5.0000	0.0000	0.0	52.85	-10.12
	33 - 29					72.88	-13.90
	29 - 28					73.36	-24.34
L19	28 - 26.875	TP26.27x25.55x0.9	4.5000	0.0000	0.0	71.96	-24.68
	26.875 - 25.75					72.48	-25.02
	25.75 - 24.625					73.00	-25.36
L20	24.625 - 23.5	TP26.31x26.27x0.9	0.2500	0.0000	0.0	73.52	-25.71
	23.5 - 23.25 (20)					73.63	-25.81
L21	23.25 - 22.75 (21)	TP26.39x26.31x0.9	0.5000	0.0000	0.0	73.86	-25.99
L22	22.75 - 22.5 (22)	TP26.43x26.39x1.05	0.2500	0.0000	0.0	85.80	-26.09
L23	22.5 - 21.5	TP27.22x26.43x1.03	5.0000	0.0000	0.0	84.36	-26.46
	21.5 - 20.5					84.89	-26.84
	20.5 - 19.5					85.41	-27.23
	19.5 - 18.5					85.94	-27.62
L24	18.5 - 17.5	TP27.5x27.22x1	1.7500	0.0000	0.0	86.46	-28.01
	17.5 - 15.75 (24)					85.33	-28.68
L25	15.75 - 15.5 (25)	TP27.54x27.5x1.08	0.2500	0.0000	0.0	91.60	-28.81
L26	15.5 - 14.4167	TP28.05x27.54x1.06	3.2500	0.0000	0.0	91.17	-29.26
	14.4167 - 13.3333					91.76	-29.72
	13.3333 - 12.25					92.35	-30.19
L27	12.25 - 12 (27)	TP28.09x28.05x0.95	0.2500	0.0000	0.0	83.04	-30.30
L28	12 - 11.75 (28)	TP28.13x28.09x0.95	0.2500	0.0000	0.0	83.16	-30.40
L29	11.75 - 11.5 (29)	TP28.17x28.13x0.75	0.2500	0.0000	0.0	66.23	-30.50
L30	11.5 - 10.5	TP28.97x28.17x0.74	5.0000	0.0000	0.0	65.53	-30.86
	10.5 - 9.5					65.91	-31.25
	9.5 - 8.5					66.29	-31.63
	8.5 - 7.5					66.66	-32.02
L31	7.5 - 6.5	TP29.05x28.97x0.74	0.5000	0.0000	0.0	67.04	-32.41
	6.5 - 6 (31)					67.23	-32.61
L32	6 - 5.75 (32)	TP29.09x29.05x0.75	0.2500	0.0000	0.0	68.43	-32.72
L33	5.75 - 4.5 (33)	TP29.29x29.09x0.75	1.2500	0.0000	0.0	68.91	-33.22
L34	4.5 - 4.25 (34)	TP29.33x29.29x0.8	0.2500	0.0000	0.0	73.48	-33.34
L35	4.25 - 3 (35)	TP29.52x29.33x0.8	1.2500	0.0000	0.0	73.99	-33.84
L36	3 - 2.75 (36)	TP29.56x29.52x0.8	0.2500	0.0000	0.0	74.09	-33.96
L37	2.75 - 1.75 (37)	TP29.72x29.56x0.8	1.0000	0.0000	0.0	74.50	-34.35
L38	1.75 - 1.5 (38)	TP29.76x29.72x0.78	0.2500	0.0000	0.0	72.34	-34.46
L39	1.5 - 1.25 (39)	TP29.8x29.76x0.78	0.2500	0.0000	0.0	72.44	-34.56
L40	1.25 - 1 (40)	TP29.84x29.8x0.8	0.2500	0.0000	0.0	74.81	-34.64
L41	1 - 0 (41)	TP30x29.84x0.8	1.0000	0.0000	0.0	75.22	-34.98

Pole Bending Design Data

Section No.	Elevation ft	Size	M_{ux} kip-ft
L1	100 - 99	TP15.79x15x0.19	20.97
	99 - 98		28.59
	98 - 97		35.85
	97 - 96		43.18
	96 - 95		50.57
L2	95 - 94	TP16.59x15.79x0.19	58.04

Section No.	Elevation ft	Size	M_{ux} kip-ft
	94 - 93		66.57
	93 - 92		75.18
	92 - 91		83.86
	91 - 90		92.61
L3	90 - 88.875	TP17.3x16.59x0.19	102.58
	88.875 - 87.75		112.68
	87.75 - 86.625		122.93
L4	86.625 - 85.5		133.31
	85.5 - 85.25	TP17.34x17.3x0.6	135.64
	(4)		
L5	85.25 - 84.25	TP18.13x17.34x0.58	145.04
	84.25 - 83.25		171.95
	83.25 - 82.25		187.91
	82.25 - 81.25		204.01
	81.25 - 80.25		220.24
L6	80.25 - 79.25	TP18.93x18.13x0.55	236.61
	79.25 - 78.25		253.11
	78.25 - 77.25		269.76
	77.25 - 76.25		286.55
	76.25 - 75.25		303.48
L7	75.25 - 74.25	TP19.72x18.93x0.54	320.55
	74.25 - 73.25		340.32
	73.25 - 72.25		361.14
	72.25 - 71.25		382.11
	71.25 - 70.25		403.21
L8	70.25 - 69	TP20.95x19.72x0.52	429.79
	69 - 67.75		456.58
	67.75 - 66.5		483.59
	66.5 - 62.5		281.13
L9	66.5 - 62.5	TP20.73x19.94x0.58	290.52
	62.5 - 61.5		594.07
L10	61.5 - 60.5	TP21.53x20.73x0.56	616.62
	60.5 - 59.5		639.30
	59.5 - 58.5		662.12
	58.5 - 57.5		685.07
	57.5 - 56.5		708.17
L11	56.5 - 54.75	TP21.81x21.53x0.56	748.91
	(11)		
L12	54.75 - 54.5	TP21.85x21.81x0.74	754.76
	(12)		
L13	54.5 - 53.5	TP22.64x21.85x0.71	778.27
	53.5 - 52.5		801.93
	52.5 - 51.5		825.73
	51.5 - 50.5		849.67
	50.5 - 49.5		873.75
L14	49.5 - 48.5	TP23.44x22.64x0.69	897.98
	48.5 - 47.5		922.35
	47.5 - 46.5		946.85
	46.5 - 45.5		971.50
	45.5 - 44.5		996.28
L15	44.5 - 43.5	TP24.23x23.44x0.68	1021.21
	43.5 - 42.5		1046.26
	42.5 - 41.5		1071.45
	41.5 - 40.5		1096.78
	40.5 - 39.5		1122.24
L16	39.5 - 38.5	TP25.03x24.23x0.65	1147.84
	38.5 - 37.5		1173.57
	37.5 - 36.5		1199.42
	36.5 - 35.5		1225.40
	35.5 - 34.5		1251.52
L17	34.5 - 33	TP25.9x25.03x0.65	1290.93
	33 - 29		609.59
L18	33 - 29	TP25.55x24.76x0.93	788.37
	29 - 28		1425.14
L19	28 - 26.875	TP26.27x25.55x0.9	1455.91
	26.875 - 25.75		1486.86

Section No.	Elevation ft	Size	M_{ux} kip-ft
	25.75 - 24.625		1518.00
L20	24.625 - 23.5 (20)	TP26.31x26.27x0.9	1549.32 1556.31
L21	23.25 - 22.75 (21)	TP26.39x26.31x0.9	1570.31
L22	22.75 - 22.5 (22)	TP26.43x26.39x1.05	1577.32
L23	22.5 - 21.5 21.5 - 20.5 20.5 - 19.5 19.5 - 18.5 18.5 - 17.5	TP27.22x26.43x1.03	1605.46 1633.75 1662.18 1690.75 1719.47
L24	17.5 - 15.75 (24)	TP27.5x27.22x1	1770.08
L25	15.75 - 15.5 (25)	TP27.54x27.5x1.08	1777.33
L26	15.5 - 14.4167 14.4167 - 13.3333 13.3333 - 12.25	TP28.05x27.54x1.06	1808.92 1840.65 1872.55
L27	12.25 - 12 (27)	TP28.09x28.05x0.95	1879.94
L28	12 - 11.75 (28)	TP28.13x28.09x0.95	1887.33
L29	11.75 - 11.5 (29)	TP28.17x28.13x0.75	1894.73
L30	11.5 - 10.5 10.5 - 9.5 9.5 - 8.5 8.5 - 7.5 7.5 - 6.5	TP28.97x28.17x0.74	1924.42 1954.22 1984.15 2014.21 2044.38
L31	6.5 - 6 (31)	TP29.05x28.97x0.74	2059.53
L32	6 - 5.75 (32)	TP29.09x29.05x0.75	2067.10
L33	5.75 - 4.5 (33)	TP29.29x29.09x0.75	2105.12
L34	4.5 - 4.25 (34)	TP29.33x29.29x0.8	2112.74
L35	4.25 - 3 (35)	TP29.52x29.33x0.8	2150.97
L36	3 - 2.75 (36)	TP29.56x29.52x0.8	2158.65
L37	2.75 - 1.75 (37)	TP29.72x29.56x0.8	2189.40
L38	1.75 - 1.5 (38)	TP29.76x29.72x0.78	2197.11
L39	1.5 - 1.25 (39)	TP29.8x29.76x0.78	2204.82
L40	1.25 - 1 (40)	TP29.84x29.8x0.8	2212.53
L41	1 - 0 (41)	TP30x29.84x0.8	2243.39

Pole Shear Design Data

Section No.	Elevation ft	Size	Actual V_u K
L1	100 - 99 99 - 98 98 - 97 97 - 96 96 - 95	TP15.79x15x0.19	6.80 7.23 7.30 7.36 7.43
L2	95 - 94 94 - 93 93 - 92 92 - 91 91 - 90	TP16.59x15.79x0.19	7.51 8.57 8.65 8.72 8.80
L3	90 - 88.875	TP17.3x16.59x0.19	8.92

Section No.	Elevation ft	Size	Actual V_u K
	88.875 - 87.75		9.05
	87.75 - 86.625		9.18
L4	86.625 - 85.5		9.30
	85.5 - 85.25	TP17.34x17.3x0.6	9.34
	(4)		
L5	85.25 - 84.25	TP18.13x17.34x0.58	9.47
	84.25 - 83.25		15.90
	83.25 - 82.25		16.03
	82.25 - 81.25		16.17
	81.25 - 80.25		16.31
L6	80.25 - 79.25	TP18.93x18.13x0.55	16.45
	79.25 - 78.25		16.59
	78.25 - 77.25		16.73
	77.25 - 76.25		16.87
	76.25 - 75.25		17.01
L7	75.25 - 74.25	TP19.72x18.93x0.54	17.15
	74.25 - 73.25		20.77
	73.25 - 72.25		20.91
	72.25 - 71.25		21.05
	71.25 - 70.25		21.18
L8	70.25 - 69	TP20.95x19.72x0.52	21.36
	69 - 67.75		21.53
	67.75 - 66.5		21.71
	66.5 - 62.5		11.15
L9	66.5 - 62.5	TP20.73x19.94x0.58	11.22
	62.5 - 61.5		22.49
L10	61.5 - 60.5	TP21.53x20.73x0.56	22.63
	60.5 - 59.5		22.77
	59.5 - 58.5		22.90
	58.5 - 57.5		23.04
	57.5 - 56.5		23.18
L11	56.5 - 54.75	TP21.81x21.53x0.56	23.43
	(11)		
L12	54.75 - 54.5	TP21.85x21.81x0.74	23.45
	(12)		
L13	54.5 - 53.5	TP22.64x21.85x0.71	23.60
	53.5 - 52.5		23.74
	52.5 - 51.5		23.88
	51.5 - 50.5		24.03
	50.5 - 49.5		24.17
L14	49.5 - 48.5	TP23.44x22.64x0.69	24.31
	48.5 - 47.5		24.45
	47.5 - 46.5		24.59
	46.5 - 45.5		24.73
	45.5 - 44.5		24.87
L15	44.5 - 43.5	TP24.23x23.44x0.68	25.01
	43.5 - 42.5		25.14
	42.5 - 41.5		25.28
	41.5 - 40.5		25.41
	40.5 - 39.5		25.55
L16	39.5 - 38.5	TP25.03x24.23x0.65	25.68
	38.5 - 37.5		25.81
	37.5 - 36.5		25.94
	36.5 - 35.5		26.07
	35.5 - 34.5		26.20
L17	34.5 - 33	TP25.9x25.03x0.65	26.41
	33 - 29		12.03
L18	33 - 29	TP25.55x24.76x0.93	15.12
	29 - 28		27.28
L19	28 - 26.875	TP26.27x25.55x0.9	27.45
	26.875 - 25.75		27.61
	25.75 - 24.625		27.78
	24.625 - 23.5		27.94
L20	23.5 - 23.25	TP26.31x26.27x0.9	27.96
	(20)		

Section No.	Elevation ft	Size	Actual V_u K
L21	23.25 - 22.75 (21)	TP26.39x26.31x0.9	28.04
L22	22.75 - 22.5 (22)	TP26.43x26.39x1.05	28.07
L23	22.5 - 21.5 21.5 - 20.5 20.5 - 19.5 19.5 - 18.5 18.5 - 17.5	TP27.22x26.43x1.03	28.23 28.37 28.52 28.66 28.81
L24	17.5 - 15.75 (24)	TP27.5x27.22x1	29.06
L25	15.75 - 15.5 (25)	TP27.54x27.5x1.08	29.08
L26	15.5 - 14.4167 14.4167 - 13.3333 13.3333 - 12.25	TP28.05x27.54x1.06	29.24 29.39 29.54
L27	12.25 - 12 (27)	TP28.09x28.05x0.95	29.56
L28	12 - 11.75 (28)	TP28.13x28.09x0.95	29.59
L29	11.75 - 11.5 (29)	TP28.17x28.13x0.75	29.63
L30	11.5 - 10.5 10.5 - 9.5 9.5 - 8.5 8.5 - 7.5 7.5 - 6.5	TP28.97x28.17x0.74	29.77 29.89 30.02 30.14 30.26
L31	6.5 - 6 (31)	TP29.05x28.97x0.74	30.31
L32	6 - 5.75 (32)	TP29.09x29.05x0.75	30.34
L33	5.75 - 4.5 (33)	TP29.29x29.09x0.75	30.51
L34	4.5 - 4.25 (34)	TP29.33x29.29x0.8	30.52
L35	4.25 - 3 (35)	TP29.52x29.33x0.8	30.69
L36	3 - 2.75 (36)	TP29.56x29.52x0.8	30.70
L37	2.75 - 1.75 (37)	TP29.72x29.56x0.8	30.83
L38	1.75 - 1.5 (38)	TP29.76x29.72x0.78	30.83
L39	1.5 - 1.25 (39)	TP29.8x29.76x0.78	30.84
L40	1.25 - 1 (40)	TP29.84x29.8x0.8	30.85
L41	1 - 0 (41)	TP30x29.84x0.8	30.90

APPENDIX B
BASE LEVEL DRAWING

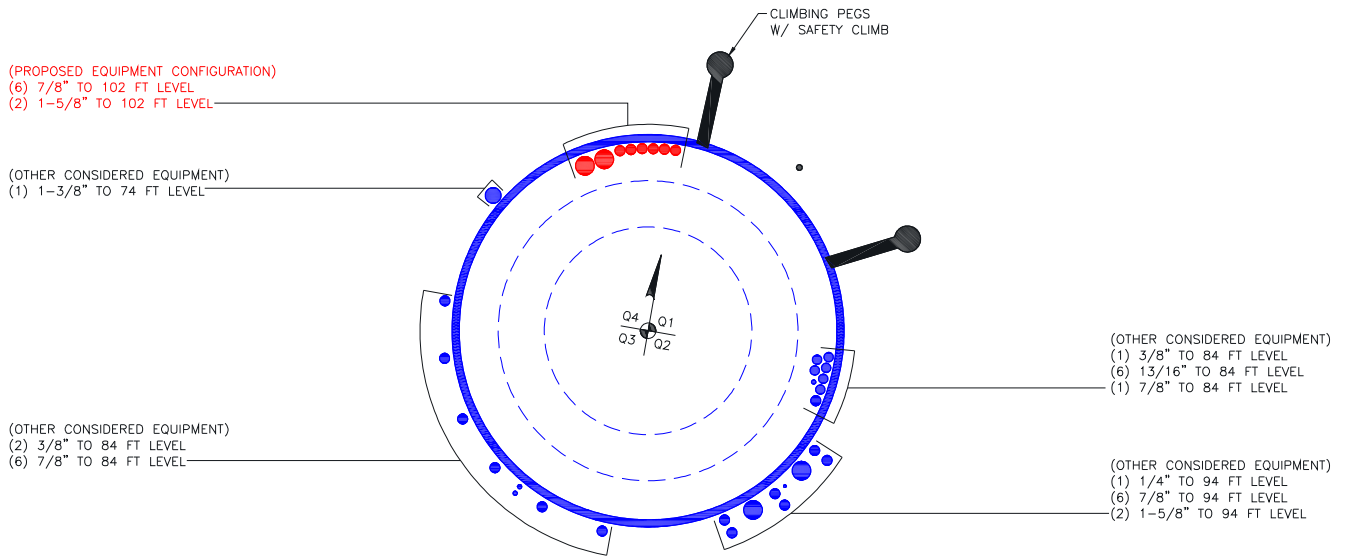

APPENDIX C
ADDITIONAL CALCULATIONS

Pole Geometry

Copyright © 2019 Crown Castle

	Pole Height Above Base (ft)	Section Length (ft)	Lap Splice Length (ft)	Number of Sides	Top Diameter (in)	Bottom Diameter (in)	Wall Thickness (in)	Bend Radius (in)	Pole Material
1	100	37.5	4	12	15	20.95	0.19	Auto	A572-65
2	66.5	37.5	4	12	19.94	25.9	0.25	Auto	A572-65
3	33	33	0	12	24.76	30	0.25	Auto	A572-65

Reinforcement Configuration

	Bottom Effective Elevation (ft)	Top Effective Elevation (ft)	Type	Model	Number	1	2	3	4	5	6	7	8	9	10	11	12
1	1.75	54.75	channel	MP3-06 (1.1875")	2	o				o							
2	1.75	15.75	channel	MP3-06 (1.1875")	1								o				
3	11.75	54.75	channel	MP3-06 (1.1875")	1									o			
4	0	1.75	plate	FP 1.25 x 2.75_1	5	c			c			c	c				c
5	12.25	32.75	channel	MP3-05 (1.1875")	1			o									
6	4.5	29.75	channel	MP3-05 (1.1875")	2							o				o	
7	54.75	85.5	channel	MP3-05 (1.1875")	3	o				o				o			
8	1.25	4.5	plate	FP 1.25 x 4.5_1	2						c					c	
9	1.25	3	plate	FP 1.25 x 4.5_1	1		c										
10	3	22.75	plate	6.5 x 1.25; (1) (1.1875)	1		o										
11	6	23.5	plate	FP 6 x 1; (1) (1.1875)	2						o						o
12	0	6	plate	FP 1.25 x 7.375_1	2						o						o
13	0	1.25	solid round	Round; (2.25 Max); (2	3		c				c				c		
14																	

Reinforcement Details

	B (in)	H (in)	Gross Area (in ²)	Pole Face to Centroid (in)	Bottom Termination Type	Bottom Termination Length (in)	Top Termination Type	Top Termination Length (in)	Lu (in)	Net Area (in ²)	Bolt Hole Size (in)	Reinforcement Material
1	6.89	2.61	8.47	0.93	PC 8.8 - M20 (100)	41	PC 8.8 - M20 (100)	41.000	24.000	7.670	1.1875	A572-65
2	6.89	2.61	8.47	0.93	PC 8.8 - M20 (100)	41	PC 8.8 - M20 (100)	41.000	24.000	7.670	1.1875	A572-65
3	6.89	2.61	8.47	0.93	PC 8.8 - M20 (100)	41	PC 8.8 - M20 (100)	41.000	24.000	7.670	1.1875	A572-65
4	1.25	2.75	3.4375	1.375	None	n/a	None	n/a	0.000	3.438	0.0000	A572-65
5	5.33	2.09	5.65	0.79	PC 8.8 - M20 (100)	29	PC 8.8 - M20 (100)	29.000	18.000	5.025	1.1875	A572-65
6	5.33	2.09	5.65	0.79	PC 8.8 - M20 (100)	29	PC 8.8 - M20 (100)	29.000	18.000	5.025	1.1875	A572-65
7	5.33	2.09	5.65	0.79	PC 8.8 - M20 (100)	29	PC 8.8 - M20 (100)	29.000	18.000	5.025	1.1875	A572-65
8	1.25	4.5	5.625	2.25	None	n/a	None	n/a	0.000	5.625	0.0000	A572-65
9	1.25	4.5	5.625	2.25	None	n/a	None	n/a	0.000	5.625	0.0000	A572-65
10	6.5	1.25	8.125	0.625	PC 8.8 - M20 (100)	33	PC 8.8 - M20 (100)	33.000	19.250	6.563	1.1875	A572-65
11	6	1	6	0.5	PC 8.8 - M20 (100)	24	PC 8.8 - M20 (100)	24.000	16.375	4.750	1.1875	A572-65
12	1.25	7.375	9.21875	3.6875	None	n/a	None	n/a	0.000	9.219	0.0000	A572-65
13	-	-	3.97608	6.875	Capacity Input	n/a	Capacity Input	n/a	0.000	3.976	0.0000	A193 Gr B7

Connection Details for Custom Reinforcements

Reinforcement	End	# Bolts	N or X	Bolt Spacing (in)	Edge Dist (in)	Weld Grade (ksi)	Transverse (Horiz.) Weld Type	Horiz. Weld Length (in)	Horiz. Groove Depth (in)	Horiz. Groove Angle (deg)	Horiz. Fillet Size (in)	Vertical Weld Length (in)	Vertical Fillet Size (in)	Rev H Connection Capacity (kip)
FP 1.25 x 2.75_1	Top	-	-	-	-	-	-	-	-	-	-	-	-	-
	Bottom	-	-	-	-	-	-	-	-	-	-	-	-	-
FP 1.25 x 4.5_1	Top	-	-	-	-	-	-	-	-	-	-	-	-	-
	Bottom	-	-	-	-	-	-	-	-	-	-	-	-	-
FP 6.5 x 1.25; (1) (1.1875)_1	Top	11	N	3	3	-	-	-	-	-	-	-	-	-
	Bottom	11	N	3	3	-	-	-	-	-	-	-	-	-
FP 6 x 1; (1) (1.1875)_1	Top	8	N	3	3	-	-	-	-	-	-	-	-	-
	Bottom	8	N	3	3	-	-	-	-	-	-	-	-	-
FP 1.25 x 7.375_1	Top	-	-	-	-	-	-	-	-	-	-	-	-	-
	Bottom	-	-	-	-	-	-	-	-	-	-	-	-	-
2.25 Solid Round; (2.25 Max); (2.25	Top	-	-	-	-	-	-	-	-	-	-	-	-	325
	Bottom	-	-	-	-	-	-	-	-	-	-	-	-	325

TNX Geometry Input

Increment (ft): [Export to TNX](#)

	Section Height (ft)	Section Length (ft)	Lap Splice Length (ft)	Number of Sides	Top Diameter (in)	Bottom Diameter (in)	Wall Thickness (in)	Tapered Pole Grade	Weight Multiplier
1	100 - 95	5		12	15.000	15.793	0.19	A572-65	1.000
2	95 - 90	5		12	15.793	16.587	0.19	A572-65	1.000
3	90 - 85.5	4.5		12	16.587	17.301	0.19	A572-65	1.000
4	85.5 - 85.25	0.25		12	17.301	17.340	0.6025	A572-65	0.846
5	85.25 - 80.25	5		12	17.340	18.134	0.5775	A572-65	0.856
6	80.25 - 75.25	5		12	18.134	18.927	0.5525	A572-65	0.870
7	75.25 - 70.25	5		12	18.927	19.720	0.54	A572-65	0.867
8	70.25 - 66.5	7.75	4	12	19.720	20.950	0.52125	A572-65	0.882
9	66.5 - 61.5	5		12	19.940	20.735	0.575	A572-65	0.897
10	61.5 - 56.5	5		12	20.735	21.529	0.5625	A572-65	0.898
11	56.5 - 54.75	1.75		12	21.529	21.807	0.5625	A572-65	0.892
12	54.75 - 54.5	0.25		12	21.807	21.847	0.7375	A572-65	0.854
13	54.5 - 49.5	5		12	21.847	22.642	0.7125	A572-65	0.864
14	49.5 - 44.5	5		12	22.642	23.437	0.6875	A572-65	0.876
15	44.5 - 39.5	5		12	23.437	24.231	0.675	A572-65	0.874
16	39.5 - 34.5	5		12	24.231	25.026	0.65	A572-65	0.890
17	34.5 - 33	5.5	4	12	25.026	25.900	0.65	A572-65	0.885
18	33 - 28	5		12	24.760	25.554	0.925	A572-65	0.856
19	28 - 23.5	4.5		12	25.554	26.268	0.9	A572-65	0.862
20	23.5 - 23.25	0.25		12	26.268	26.308	0.9	A572-65	1.024
21	23.25 - 22.75	0.5		12	26.308	26.388	0.9	A572-65	1.022
22	22.75 - 22.5	0.25		12	26.388	26.427	1.05	A572-65	0.975
23	22.5 - 17.5	5		12	26.427	27.221	1.025	A572-65	0.975
24	17.5 - 15.75	1.75		12	27.221	27.499	1	A572-65	0.990
25	15.75 - 15.5	0.25		12	27.499	27.539	1.075	A572-65	1.015
26	15.5 - 12.25	3.25		12	27.539	28.055	1.0625	A572-65	1.012
27	12.25 - 12	0.25		12	28.055	28.095	0.95	A572-65	1.058
28	12 - 11.75	0.25		12	28.095	28.134	0.95	A572-65	1.056
29	11.75 - 11.5	0.25		12	28.134	28.174	0.75	A572-65	1.199
30	11.5 - 6.5	5		12	28.174	28.968	0.7375	A572-65	1.194
31	6.5 - 6	0.5		12	28.968	29.047	0.7375	A572-65	1.191
32	6 - 5.75	0.25		12	29.047	29.087	0.75	A572-65	1.265
33	5.75 - 4.5	1.25		12	29.087	29.285	0.75	A572-65	1.259
34	4.5 - 4.25	0.25		12	29.285	29.325	0.8	A572-65	1.180
35	4.25 - 3	1.25		12	29.325	29.524	0.8	A572-65	1.174
36	3 - 2.75	0.25		12	29.524	29.563	0.8	A572-65	1.139
37	2.75 - 1.75	1		12	29.563	29.722	0.8	A572-65	1.135
38	1.75 - 1.5	0.25		12	29.722	29.762	0.775	A572-65	1.055
39	1.5 - 1.25	0.25		12	29.762	29.802	0.775	A572-65	1.054
40	1.25 - 1	0.25		12	29.802	29.841	0.8	A572-65	0.955
41	1 - 0	1		12	29.841	30.000	0.8	A572-65	0.951

TNX Section Forces

Increment (ft):		TNX Output			
	5	Section Height (ft)	P _u (K)	M _{ux} (kip-ft)	V _u (K)
1		100 - 95	3.82	50.57	7.43
2		95 - 90	5.02	92.61	8.80
3		90 - 85.5	5.25	133.31	9.30
4		85.5 - 85.25	5.29	135.64	9.34
5		85.25 - 80.25	9.86	220.24	16.31
6		80.25 - 75.25	10.52	303.48	17.01
7		75.25 - 70.25	14.14	403.21	21.18
8		70.25 - 66.5	14.71	483.59	21.71
9		66.5 - 61.5	16.00	594.07	22.49
10		61.5 - 56.5	16.90	708.17	23.18
11		56.5 - 54.75	17.21	748.91	23.43
12		54.75 - 54.5	17.29	754.76	23.45
13		54.5 - 49.5	18.36	873.75	24.17
14		49.5 - 44.5	19.47	996.28	24.87
15		44.5 - 39.5	20.61	1122.24	25.55
16		39.5 - 34.5	21.79	1251.51	26.20
17		34.5 - 33	22.14	1290.93	26.41
18		33 - 28	24.34	1425.14	27.28
19		28 - 23.5	25.71	1549.32	27.94
20		23.5 - 23.25	25.81	1556.31	27.96
21		23.25 - 22.75	25.99	1570.31	28.04
22		22.75 - 22.5	26.09	1577.32	28.07
23		22.5 - 17.5	28.01	1719.47	28.81
24		17.5 - 15.75	28.68	1770.07	29.06
25		15.75 - 15.5	28.81	1777.34	29.08
26		15.5 - 12.25	30.19	1872.55	29.54
27		12.25 - 12	30.30	1879.94	29.56
28		12 - 11.75	30.40	1887.33	29.59
29		11.75 - 11.5	30.50	1894.73	29.62
30		11.5 - 6.5	32.41	2044.39	30.26
31		6.5 - 6	32.61	2059.52	30.31
32		6 - 5.75	32.72	2067.10	30.34
33		5.75 - 4.5	33.22	2105.11	30.51
34		4.5 - 4.25	33.34	2112.74	30.52
35		4.25 - 3	33.84	2150.98	30.69
36		3 - 2.75	33.96	2158.65	30.70
37		2.75 - 1.75	34.35	2189.40	30.83
38		1.75 - 1.5	34.46	2197.11	30.83
39		1.5 - 1.25	34.56	2204.82	30.84
40		1.25 - 1	34.64	2212.53	30.85
41		1 - 0	34.98	2243.39	30.90

Analysis Results

Elevation (ft)	Component Type	Size	Critical Element	% Capacity	Pass / Fail
100 - 95	Pole	TP15.793x15x0.19	Pole	22.4%	Pass
95 - 90	Pole	TP16.587x15.793x0.19	Pole	37.3%	Pass
90 - 85.5	Pole	TP17.301x16.587x0.19	Pole	49.7%	Pass
85.5 - 85.25	Pole + Reinf.	TP17.34x17.301x0.6025	Reinf. 7 Tension Rupture	24.7%	Pass
85.25 - 80.25	Pole + Reinf.	TP18.134x17.34x0.5775	Reinf. 7 Tension Rupture	37.9%	Pass
80.25 - 75.25	Pole + Reinf.	TP18.927x18.134x0.5525	Reinf. 7 Tension Rupture	49.2%	Pass
75.25 - 70.25	Pole + Reinf.	TP19.72x18.927x0.54	Reinf. 7 Tension Rupture	61.9%	Pass
70.25 - 66.5	Pole + Reinf.	TP20.95x19.72x0.5213	Reinf. 7 Tension Rupture	71.1%	Pass
66.5 - 61.5	Pole + Reinf.	TP20.735x19.94x0.575	Reinf. 7 Tension Rupture	75.9%	Pass
61.5 - 56.5	Pole + Reinf.	TP21.529x20.735x0.5625	Reinf. 7 Tension Rupture	85.5%	Pass
56.5 - 54.75	Pole + Reinf.	TP21.807x21.529x0.5625	Reinf. 7 Tension Rupture	88.7%	Pass
54.75 - 54.5	Pole + Reinf.	TP21.847x21.807x0.7375	Reinf. 3 Tension Rupture	68.4%	Pass
54.5 - 49.5	Pole + Reinf.	TP22.642x21.847x0.7125	Reinf. 3 Tension Rupture	75.5%	Pass
49.5 - 44.5	Pole + Reinf.	TP23.437x22.642x0.6875	Reinf. 3 Tension Rupture	82.1%	Pass
44.5 - 39.5	Pole + Reinf.	TP24.231x23.437x0.675	Reinf. 3 Tension Rupture	88.3%	Pass
39.5 - 34.5	Pole + Reinf.	TP25.026x24.231x0.65	Reinf. 3 Tension Rupture	94.2%	Pass
34.5 - 33	Pole + Reinf.	TP25.9x25.026x0.65	Reinf. 3 Tension Rupture	95.8%	Pass
33 - 28	Pole + Reinf.	TP25.554x24.76x0.925	Reinf. 5 Tension Rupture	76.2%	Pass
28 - 23.5	Pole + Reinf.	TP26.268x25.554x0.9	Reinf. 5 Tension Rupture	80.0%	Pass
23.5 - 23.25	Pole + Reinf.	TP26.308x26.268x0.9	Reinf. 5 Tension Rupture	79.6%	Pass
23.25 - 22.75	Pole + Reinf.	TP26.388x26.308x0.9	Reinf. 5 Tension Rupture	80.0%	Pass
22.75 - 22.5	Pole + Reinf.	TP26.427x26.388x1.05	Reinf. 3 Tension Rupture	73.4%	Pass
22.5 - 17.5	Pole + Reinf.	TP27.221x26.427x1.025	Reinf. 3 Tension Rupture	77.1%	Pass
17.5 - 15.75	Pole + Reinf.	TP27.499x27.221x1	Reinf. 3 Tension Rupture	78.4%	Pass
15.75 - 15.5	Pole + Reinf.	TP27.539x27.499x1.075	Reinf. 6 Tension Rupture	68.5%	Pass
15.5 - 12.25	Pole + Reinf.	TP28.055x27.539x1.0625	Reinf. 6 Tension Rupture	70.6%	Pass
12.25 - 12	Pole + Reinf.	TP28.095x28.055x0.95	Reinf. 1 Tension Rupture	78.6%	Pass
12 - 11.75	Pole + Reinf.	TP28.134x28.095x0.95	Reinf. 1 Tension Rupture	78.8%	Pass
11.75 - 11.5	Pole + Reinf.	TP28.174x28.134x0.75	Reinf. 6 Tension Rupture	91.0%	Pass
11.5 - 6.5	Pole + Reinf.	TP28.968x28.174x0.7375	Reinf. 6 Tension Rupture	94.6%	Pass
6.5 - 6	Pole + Reinf.	TP29.047x28.968x0.7375	Reinf. 6 Tension Rupture	95.0%	Pass
6 - 5.75	Pole + Reinf.	TP29.087x29.047x0.75	Reinf. 10 Tension Rupture	88.0%	Pass
5.75 - 4.5	Pole + Reinf.	TP29.285x29.087x0.75	Reinf. 10 Tension Rupture	88.9%	Pass
4.5 - 4.25	Pole + Reinf.	TP29.325x29.285x0.8	Reinf. 8 Tension Yield	88.9%	Pass
4.25 - 3	Pole + Reinf.	TP29.524x29.325x0.8	Reinf. 8 Tension Yield	89.7%	Pass
3 - 2.75	Pole + Reinf.	TP29.563x29.524x0.8	Reinf. 9 Tension Yield	91.2%	Pass
2.75 - 1.75	Pole + Reinf.	TP29.722x29.563x0.8	Reinf. 9 Tension Yield	91.8%	Pass
1.75 - 1.5	Pole + Reinf.	TP29.762x29.722x0.775	Reinf. 9 Tension Yield	97.2%	Pass
1.5 - 1.25	Pole + Reinf.	TP29.802x29.762x0.775	Reinf. 9 Tension Yield	97.4%	Pass
1.25 - 1	Pole + Reinf.	TP29.841x29.802x0.8	Reinf. 4 Tension Yield	88.3%	Pass
1 - 0	Pole + Reinf.	TP30x29.841x0.8	Reinf. 4 Tension Yield	89.0%	Pass
				Summary	
			Pole	80.7%	Pass
			Reinforcement	97.4%	Pass
			Overall	97.4%	Pass

Additional Calculations

Section Elevation (ft)	Moment of Inertia (in ⁴)			Area (in ²)			% Capacity*													
	Pole	Reinf.	Total	Pole	Reinf.	Total	Pole	R1	R2	R3	R4	R5	R6	R7	R8	R9	R10	R11	R12	R13
100 - 95	297	n/a	297	9.53	n/a	9.53	22.4%													
95 - 90	345	n/a	345	10.02	n/a	10.02	37.3%													
90 - 85.5	392	n/a	392	10.45	n/a	10.45	49.7%													
85.5 - 85.25	394	769	1164	10.48	16.95	27.43	16.5%							24.7%						
85.25 - 80.25	452	834	1286	10.96	16.95	27.91	25.8%							37.9%						
80.25 - 75.25	514	902	1416	11.45	16.95	28.40	34.1%							49.2%						
75.25 - 70.25	583	972	1555	11.93	16.95	28.88	43.7%							61.9%						
70.25 - 66.5	637	1027	1664	12.30	16.95	29.25	51.0%							71.1%						
66.5 - 61.5	884	1066	1950	16.47	16.95	33.42	49.9%							75.9%						
61.5 - 56.5	991	1142	2134	17.11	16.95	34.06	56.9%							85.5%						
56.5 - 54.75	1031	1170	2200	17.33	16.95	34.28	59.3%							88.7%						
54.75 - 54.5	1036	1811	2847	17.36	25.41	42.77	46.3%	68.4%		68.4%										
54.5 - 49.5	1155	1932	3088	18.00	25.41	43.41	51.8%	75.5%		75.5%										
49.5 - 44.5	1283	2058	3341	18.64	25.41	44.05	57.1%	82.1%		82.1%										
44.5 - 39.5	1419	2188	3607	19.28	25.41	44.69	62.3%	88.3%		88.3%										
39.5 - 34.5	1565	2322	3886	19.92	25.41	45.33	67.4%	94.2%		94.2%										
34.5 - 33	1610	2362	3973	20.11	25.41	45.52	68.9%	95.8%		95.8%										
33 - 28	1667	3983	5650	20.34	42.36	62.70	54.3%	75.2%		75.2%		76.2%	76.2%							
28 - 23.5	1812	4193	6005	20.91	42.36	63.27	57.7%	78.9%		78.9%		80.0%	80.0%							
23.5 - 23.25	1821	4240	6061	20.95	54.36	75.31	57.5%	64.3%		78.5%		79.6%	65.2%						62.5%	
23.25 - 22.75	1837	4264	6101	21.01	54.36	75.37	57.9%	64.7%		79.0%		80.0%	65.5%						62.8%	
22.75 - 22.5	1871	5220	7091	21.04	62.49	83.53	55.2%	62.7%		73.4%		63.8%	66.2%					59.8%	63.4%	
22.5 - 17.5	2046	5515	7561	21.68	62.49	84.17	58.9%	65.9%		77.1%		67.1%	69.6%					62.9%	66.7%	
17.5 - 15.75	2110	5620	7730	21.90	62.49	84.39	60.1%	67.0%		78.4%		68.2%	70.8%					64.0%	67.9%	
15.75 - 15.5	2091	6175	8266	21.94	70.96	92.89	53.0%	67.7%		53.8%		63.2%	64.6%					58.3%	64.5%	
15.5 - 12.25	2212	6393	8605	22.35	70.96	93.31	55.1%	69.7%		55.5%		65.1%	66.6%					60.1%	66.5%	
12.25 - 12	2232	5646	7878	22.38	65.31	87.69	63.6%	78.6%		59.3%		70.8%	72.4%					73.6%	69.7%	
12 - 11.75	2242	5661	7903	22.41	65.31	87.72	63.7%	78.8%		59.4%		71.0%	72.6%					73.7%	69.8%	
11.75 - 11.5	2244	4186	6430	22.45	56.84	79.28	76.1%	84.5%		83.5%			91.0%					83.6%	72.8%	
11.5 - 6.5	2441	4408	6849	23.08	56.84	79.92	80.3%	88.0%		86.9%			94.6%					87.1%	75.8%	
6.5 - 6	2461	4431	6892	23.15	56.84	79.98	80.7%	88.3%		87.2%			95.0%					87.4%	76.1%	
6 - 5.75	2472	4629	7101	23.18	63.27	86.45	77.6%	77.4%		87.6%			83.4%					88.0%		58.9%
5.75 - 4.5	2523	4688	7211	23.34	63.27	86.61	78.6%	78.2%		88.4%			84.2%					88.9%		59.5%
4.5 - 4.25	2534	5096	7630	23.37	63.22	86.59	77.1%	71.7%		85.3%								87.3%		56.2%
4.25 - 3	2586	5158	7743	23.53	63.22	86.75	78.2%	72.4%		86.0%								89.7%		56.7%
3 - 2.75	2593	5255	7847	23.56	60.72	84.29	74.3%	69.3%		84.2%								86.2%	91.2%	57.5%
2.75 - 1.75	2635	5306	7941	23.69	60.72	84.41	75.1%	69.9%		84.8%								86.9%	91.8%	57.9%
1.75 - 1.5	2645	5074	7719	23.72	52.50	76.22	77.7%					92.5%						90.0%	97.2%	61.3%
1.5 - 1.25	2655	5087	7742	23.75	52.50	76.25	77.9%					92.7%						90.2%	97.4%	61.5%
1.25 - 1	2666	5416	8082	23.79	47.55	71.34	74.2%					88.3%								59.1%
1 - 0	2709	5462	8171	23.91	47.55	71.47	75.0%					89.0%								59.5%

Note: Section capacity checked assuming all reinforcements are effective and using 5 degree increments.
Rating per TIA-222-H Section 15.5.

Monopole Base Plate Connection



Site Info	
BU #	806042
Site Name	BOS ASHLAND 959026
Order #	593348 rev 1

Analysis Considerations	
TIA-222 Revision	H
Grout Considered:	Yes
I_w (in)	1.75

Applied Loads	
Moment (kip-ft)	2243.39
Axial Force (kips)	34.98
Shear Force (kips)	30.90

*TIA-222-H Section 15.5 Applied

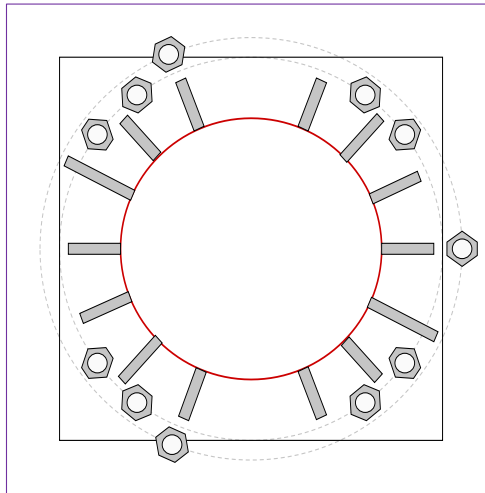

Connection Properties	Analysis Results
Anchor Rod Data GROUP 1: (8) 2-1/4" ϕ bolts (A615-75 X; Fy=75 ksi, Fu=100 ksi) on 44" BC <i>Anchor Spacing: 6.428 in</i> GROUP 2: (3) 2-1/4" ϕ bolts (F1554-105 X; Fy=105 ksi, Fu=125 ksi) on 48.5" BC	Anchor Rod Summary <i>(units of kips, kip-in)</i> GROUP 1: Pu_t = 213.75 ϕPn_t = 243.75 Stress Rating Vu = 3.86 ϕVn = 149.1 83.5% Mu = n/a ϕMn = n/a Pass GROUP 2: Pu_t = 236.96 ϕPn_t = 304.69 Stress Rating Vu = 0 ϕVn = 186.38 74.1% Mu = n/a ϕMn = n/a Pass
Base Plate Data 44" W x 2" Plate (A572-60; Fy=60 ksi, Fu=75 ksi); Clip: 0 in	Base Plate Summary Max Stress (ksi): 110.62 (Flexural) Allowable Stress (ksi): 54 Stress Rating: FEA on File Sufficient
Stiffener Data Group 1: (4) 18"H x 6"W x 1.25"T, Notch: 0.75" plate: Fy= 50 ksi ; weld: Fy= 70 ksi horiz. weld: 0.5" groove, 45° dbl bevel, 0.5" fillet vert. weld: 0.3125" fillet Group 2: (3) 54"H x 6"W x 1.25"T, Notch: 0.75" plate: Fy= 50 ksi ; weld: Fy= 70 ksi horiz. weld: 0.5" groove, 45° dbl bevel, 0.5" fillet vert. weld: 0.3125" fillet Group 3: (2) 36"H x 6"W x 1.25"T, Notch: 0.75" plate: Fy= 50 ksi ; weld: Fy= 70 ksi horiz. weld: 0.5" groove, 45° dbl bevel, 0.5" fillet vert. weld: 0.3125" fillet Group 4: (3) 48"H x 6"W x 1.25"T, Notch: 0.75" plate: Fy= 50 ksi ; weld: Fy= 80 ksi horiz. weld: 0.625" groove, 45° dbl bevel, 0.625" fillet vert. weld: 0.707" fillet Group 5: (2) 87"H x 8.4375"W x 1.25"T, Notch: 0.75" plate: Fy= 50 ksi ; weld: Fy= 80 ksi horiz. weld: 0.625" groove, 45° dbl bevel, 0.625" fillet vert. weld: 0.375" fillet	Stiffener Summary Horizontal Weld: 53.9% Pass Vertical Weld: 43.1% Pass Plate Flexure+Shear: 7.1% Pass Plate Tension+Shear: 32.6% Pass Plate Compression: 34.2% Pass Pole Summary Punching Shear: 4.6% Pass
Pole Data 30" x 0.8" 12-sided pole (A572-65; Fy=65 ksi, Fu=80 ksi)	

Base Plate FEA Results & Discussion

Analysis Software Information: ANSYS, Inc. Products Release 19.R2

RESULTS SUMMARY

ELEMENT	MATERIAL	DESIGNATION
Base Plate	Gr. 60	Sufficient

ANALYSIS APPROACH

Finite Element Analysis

This analysis has been completed by means of computer based finite element analysis (FEA). To establish the basic behavior of the connection, a finite element model (FEM) was developed with elastic material properties. If results of the elastic analysis prove to be unsatisfactory, the connection will be further analyzed with plastic (non-linear) material properties to allow for stress redistribution.

Loading

The loading applied to the connection has been done by means of three applied loads: Axial, Shear, and Moment. All loads are calculated through tnxTower. The value of the moment has been adjusted to account for the moment induced by the shear component. The applied loads within the model are a set distance from the base plate. Loading has been applied in a direction that results in the highest stresses in the connection. The applied moment has been increased by a factor of 1.11 to consider a Phi equal to 0.9.

Loading Direction:

Eight loading directions were considered in this analysis:

D1-D8) Load applied every 45° around the base plate, with the 0° datum chosen to ensure load into the corners of the base plate is considered.

Modeling Notes

- All welded surfaces have been modeled using bonded contact definitions.
- All non-welded surfaces in contact have been conservatively modeled with frictionless contact definitions.
- The bolts have been modeled using deformable ANSYS one-dimensional beam elements.
- All other structural members are modeled as ANSYS two-dimensional shell elements or three-dimensional solid elements.
- The base plate is appropriately constrained at the anchor rod locations. A compression constraint is applied to the underside of the base plate to allow for proper bending.
- The load is applied at the top of the pole section. The length of the pole section modeled is chosen to allow for proper flexural behavior of the connection.

PJF PAUL J. FORD & COMPANY

250 E Broad St, Ste 600 • Columbus, OH 43215
 Phone 614.221.6679 www.pauljford.com

(c) Copyright 2022 by Paul J. Ford and Company, all rights reserved.

PJF Project:	37522-0071.001.7805
Engineer:	RMF
Date:	3/1/2022
Site Number:	806042
Site Name:	BOS ASHLAND 959026
Work Order Number:	2047354
Order Number:	586235 Rev 0

Load Conversions For ANSYS Input (Version v1.6 - Effective Date 08/11/2020)

Analysis Levels: 1

Loading					
#	Elevation (ft)	Offset (in)	Load Type	Load From TNX (kip, kip-ft)	Load To ANSYS (lb, lb-in)
1	0.00	348.00	Moment ¹	2228.45	19,063,866.67
			Axial	36.02	36,020.00
			Shear	30.60	30,600.00

Axial/Shear Resultant: 47263.10

1. Moment accounts for $\Phi=0.9$ as well as inherent moment caused by the shear load being applied at an offset.

B: 0

0

Time: 1. s

3/1/2022 2:56 PM

- A** Compression Only Support
- B** Compression Only Support 2
- C** Fixed Support
- D** Moment: 1.9064×10^7 lbf-in
- E** Remote Force: 47263 lbf

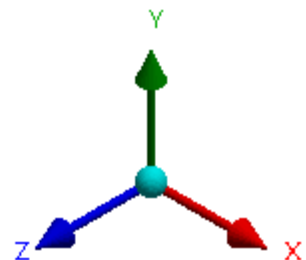
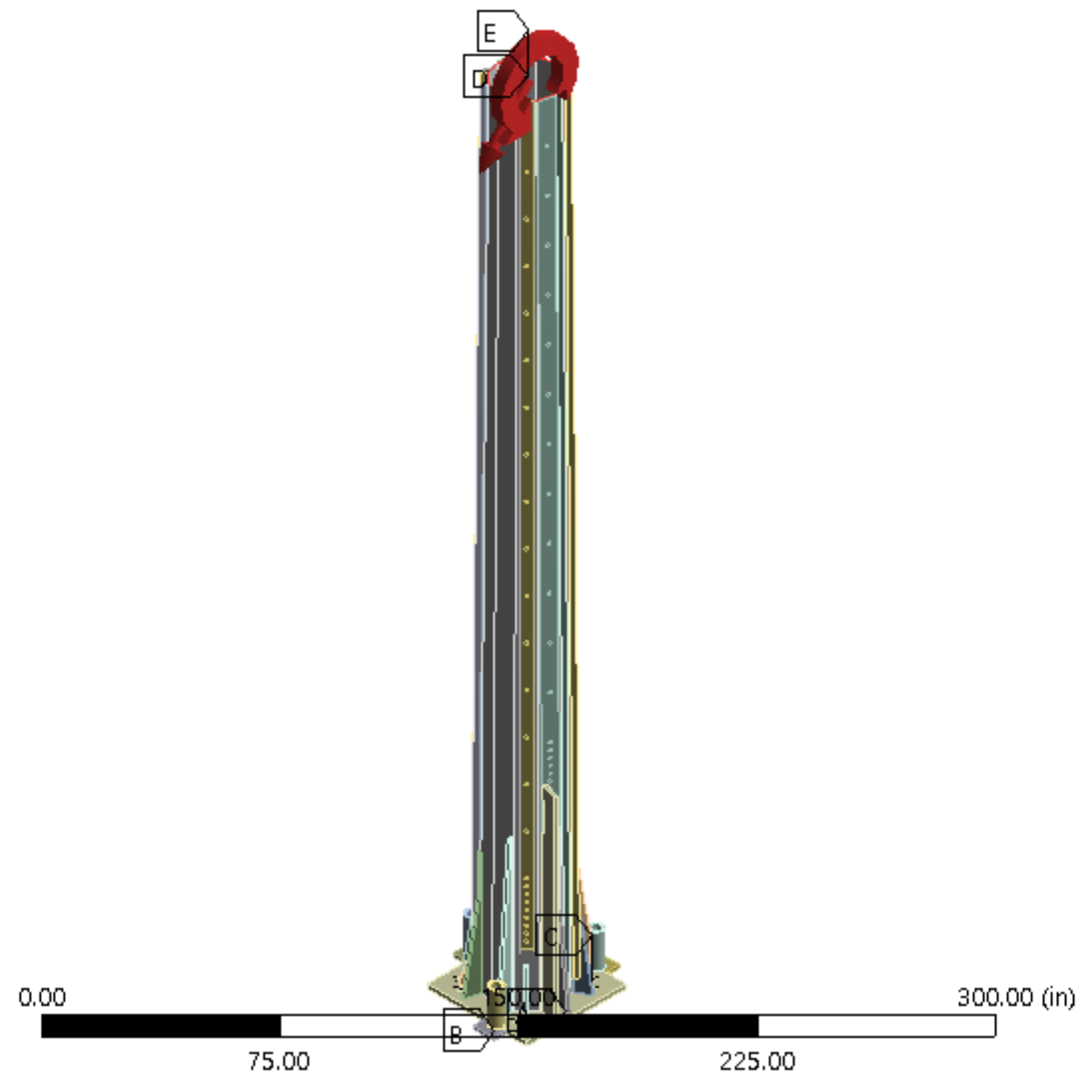

E: 225

Base Plate

Type: Equivalent (von-Mises) Stress

Unit: psi

Time: 1

3/1/2022 2:57 PM

65389 Max

60000

52500

45000

37500

30000

22500

15000

7500

4.6088 Min

0

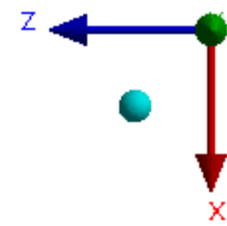
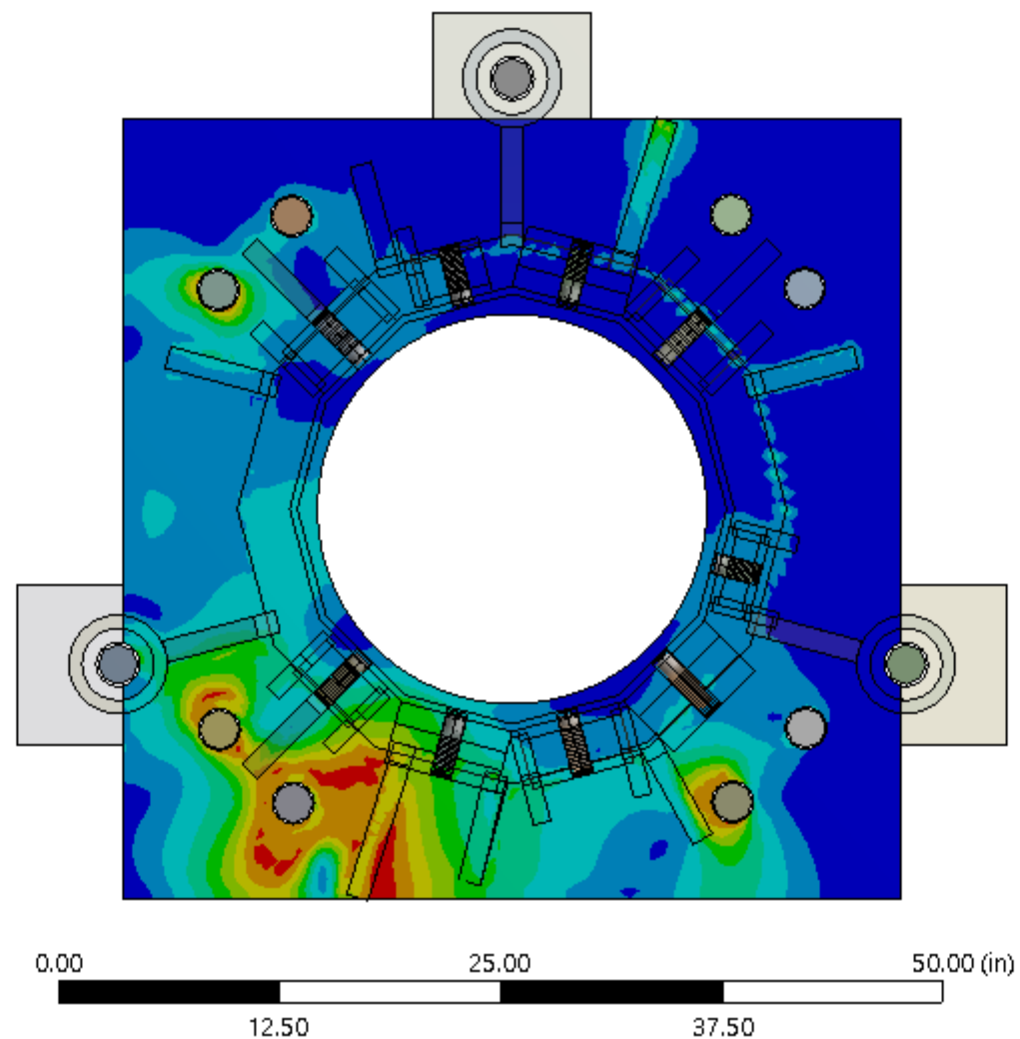

F: 270

Base Plate

Type: Equivalent (von-Mises) Stress

Unit: psi

Time: 1

3/1/2022 2:58 PM

65484 Max

60000

52500

45000

37500

30000

22500

15000

7500

2.3007 Min

0

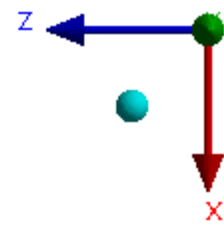
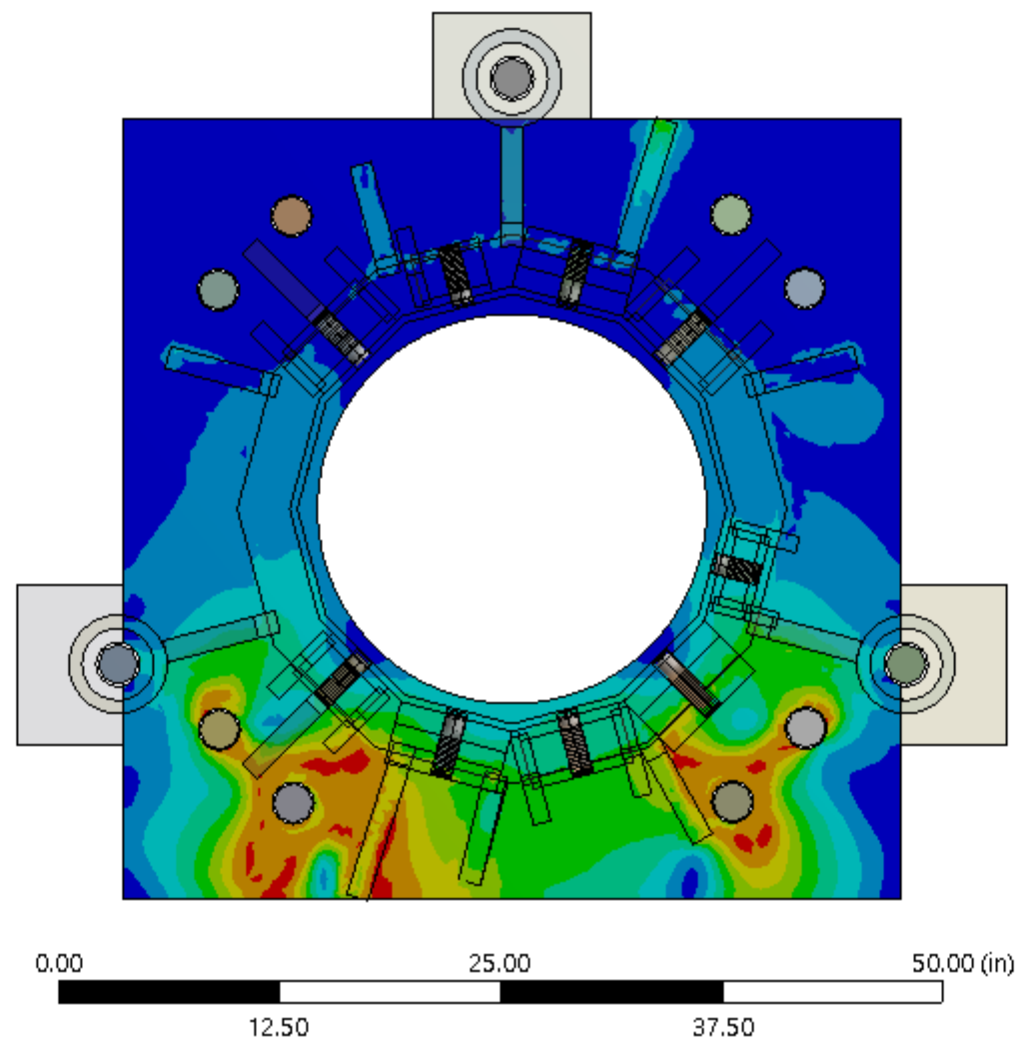

G: 315

Base Plate

Type: Equivalent (von-Mises) Stress

Unit: psi

Time: 1

3/1/2022 2:58 PM

64093 Max

60000

52500

45000

37500

30000

22500

15000

7500

3.2838 Min

0

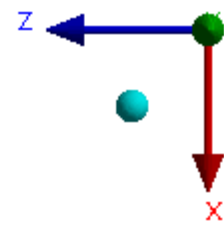
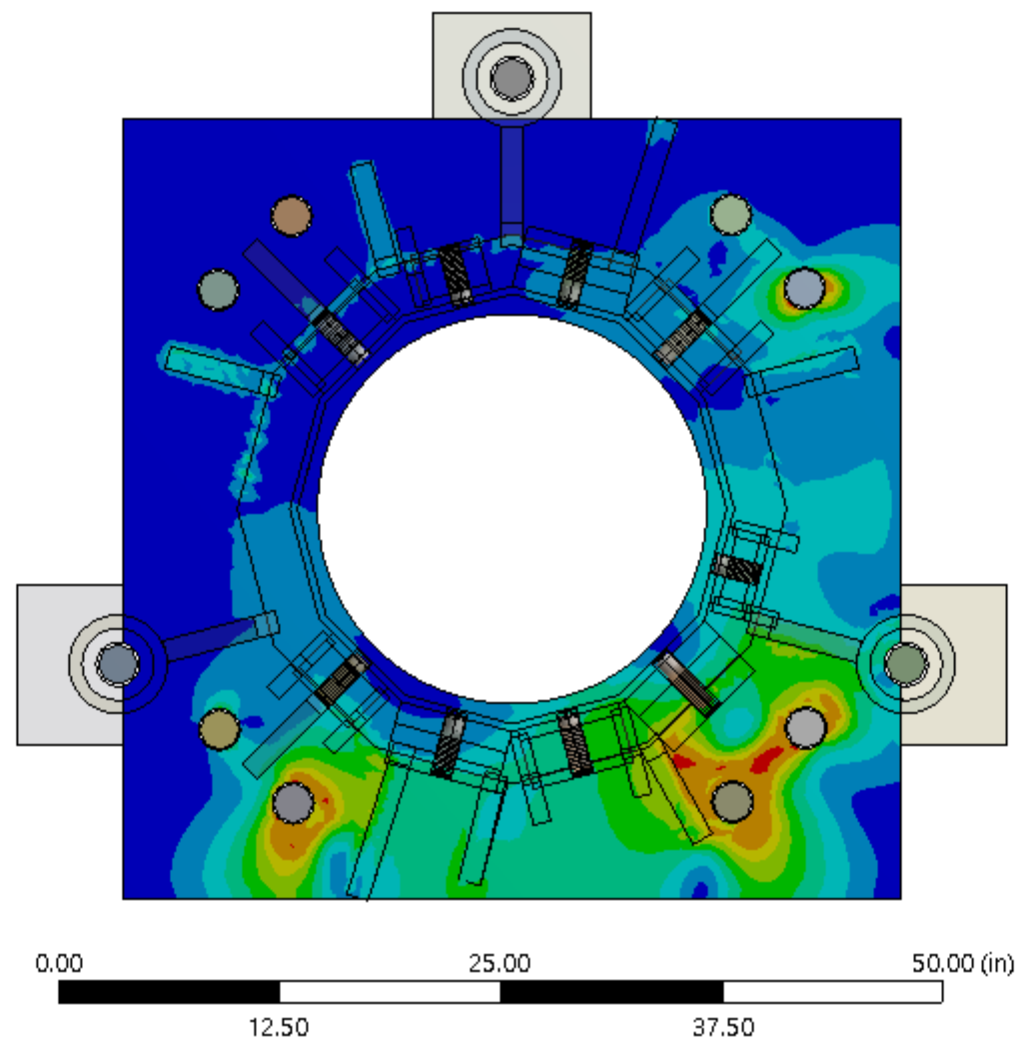

Drilled Pier Foundation

BU # :	806042
Site Name:	BOS ASHLAND 959026
Order Number:	593348 Rev 1
TIA-222 Revison:	H
Tower Type:	Monopole



Applied Loads		
	Comp.	Uplift
Moment (kip-ft)	2243.38	
Axial Force (kips)	35	
Shear Force (kips)	30.89	

Material Properties		
Concrete Strength, f _c :	3	ksi
Rebar Strength, F _y :	60	ksi
Tie Yield Strength, F _y :	40	ksi

Rebar 2, Fy
Override
(ksi)

Pier Design Data	
Depth	21.25 ft
Ext. Above Grade	0.25 ft
Pier Section 1	
<i>From 0.25' above grade to 21.25' below grade</i>	
Pier Diameter	6 ft
Rebar Quantity	46
Rebar Size	8
Clear Cover to Ties	4 in
Tie Size	4
Tie Spacing	in

Rebar & Pier Options

Embedded Pole Inputs

Belled Pier Inputs

Analysis Results

Soil Lateral Check	Compression	Uplift
D _{v=0} (ft from TOC)	6.70	-
Soil Safety Factor	1.62	-
Max Moment (kip-ft)	2451.23	-
Rating*	78.4%	-

Soil Vertical Check	Compression	Uplift
Skin Friction (kips)	282.78	-
End Bearing (kips)	424.12	-
Weight of Concrete (kips)	85.59	-
Total Capacity (kips)	706.89	-
Axial (kips)	120.59	-
Rating*	16.2%	-

Reinforced Concrete Flexure	Compression	Uplift
Critical Depth (ft from TOC)	6.64	-
Critical Moment (kip-ft)	2451.19	-
Critical Moment Capacity	4663.70	-
Rating*	50.1%	-

Reinforced Concrete Shear	Compression	Uplift
Critical Depth (ft from TOC)	15.40	-
Critical Shear (kip)	347.52	-
Critical Shear Capacity	434.11	-
Rating*	76.2%	-

Structural Foundation Rating*	76.2%
Soil Interaction Rating*	78.4%

*Rating per TIA-222-H Section 15.5

Check Limitation	
Apply TIA-222-H Section 15.5:	<input checked="" type="checkbox"/>
N/A	<input type="checkbox"/>
Additional Longitudinal Rebar	
Input Effective Depths (else Actual):	<input type="checkbox"/>
Shear Design Options	
Check Shear along Depth of Pier:	<input checked="" type="checkbox"/>
Utilize Shear-Friction Methodology:	<input type="checkbox"/>
Override Critical Depth:	<input type="checkbox"/>

[Go to Soil Calculations](#)

Soil Profile													
Groundwater Depth	10			# of Layers	3								

Layer	Top (ft)	Bottom (ft)	Thickness (ft)	Y _{soil} (pcf)	Y _{concrete} (pcf)	Cohesion (ksf)	Angle of Friction (degrees)	Calculated Ultimate Skin Friction Comp (ksf)	Calculated Ultimate Skin Friction Uplift (ksf)	Ultimate Skin Friction Comp Override (ksf)	Ultimate Skin Friction Uplift Override (ksf)	Ult. Gross Bearing Capacity (ksf)	SPT Blow Count	Soil Type
1	0	5	5	100	150	0	0	0.000	0.000	0.00	0.00			Cohesionless
2	5	10	5	120	150		32	0.904	0.904				58	Cohesionless
3	10	21.25	11.25	57.6	87.6		32	1.376	1.376			20	58	Cohesionless

ASCE 7 Hazards Report

Address:
No Address at This
Location

Standard: ASCE/SEI 7-10
Risk Category: II
Soil Class: D - Stiff Soil

Elevation: 324.94 ft (NAVD 88)
Latitude: 42.273694
Longitude: -71.451556

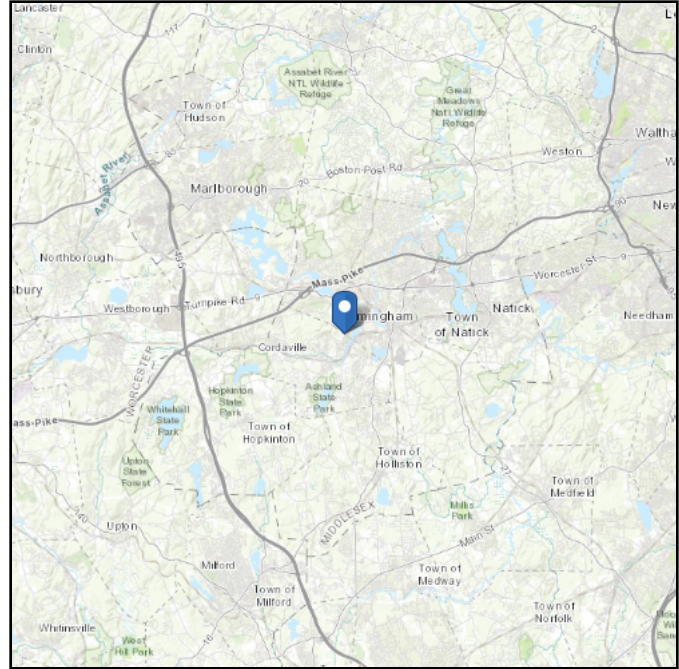
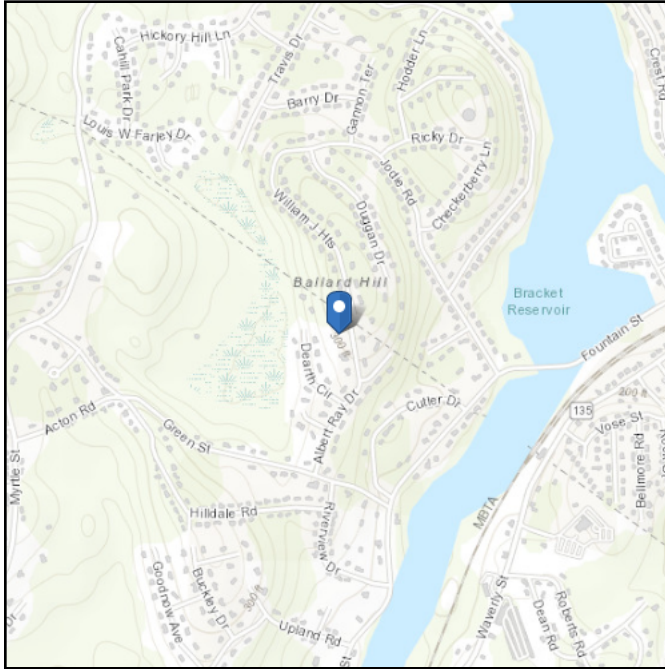

Site Soil Class: D - Stiff Soil

Results:

S_S :	0.192	S_{DS} :	0.205
S_1 :	0.067	S_{D1} :	0.107
F_a :	1.6	T_L :	6
F_v :	2.4	PGA :	0.098
S_{MS} :	0.307	PGA _M :	0.157
S_{M1} :	0.16	F _{PGA} :	1.6
		I_e :	1

Seismic Design Category B

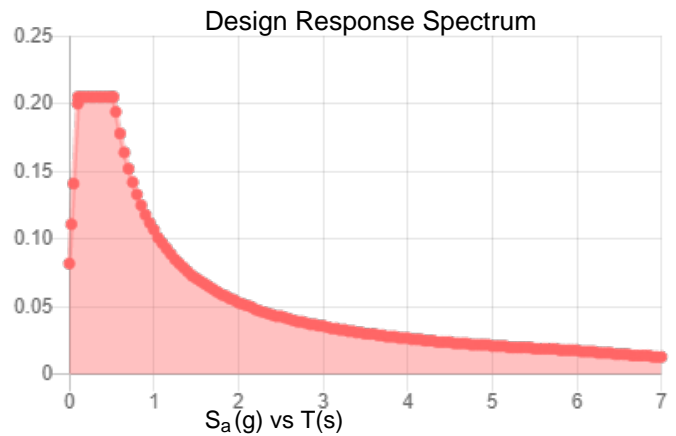
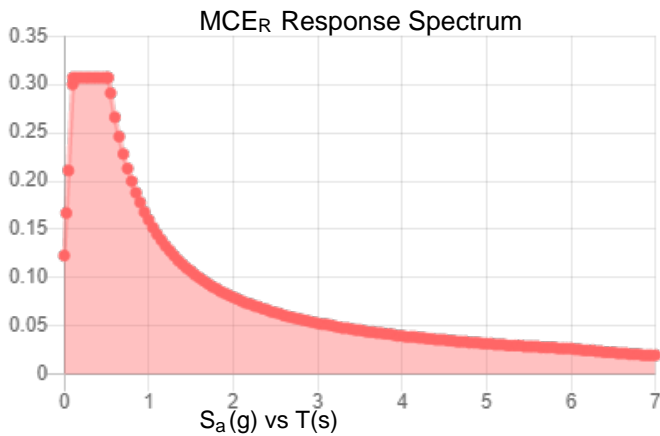

Data Accessed: Thu Feb 24 2022

Date Source:

USGS Seismic Design Maps based on ASCE/SEI 7-10, incorporating Supplement 1 and errata of March 31, 2013, and ASCE/SEI 7-10 Table 1.5-2. Additional data for site-specific ground motion procedures in accordance with ASCE/SEI 7-10 Ch. 21 are available from USGS.

Ice

Results:

Ice Thickness: 0.75 in.
Concurrent Temperature: 15 F
Gust Speed 50 mph

Data Source: Standard ASCE/SEI 7-10, Figs. 10-2 through 10-8

Date Accessed: Thu Feb 24 2022

Ice thicknesses on structures in exposed locations at elevations higher than the surrounding terrain and in valleys and gorges may exceed the mapped values.

Values provided are equivalent radial ice thicknesses due to freezing rain with concurrent 3-second gust speeds, for a 50-year mean recurrence interval, and temperatures concurrent with ice thicknesses due to freezing rain. Thicknesses for ice accretions caused by other sources shall be obtained from local meteorological studies. Ice thicknesses in exposed locations at elevations higher than the surrounding terrain and in valleys and gorges may exceed the mapped values.

The ASCE 7 Hazard Tool is provided for your convenience, for informational purposes only, and is provided “as is” and without warranties of any kind. The location data included herein has been obtained from information developed, produced, and maintained by third party providers; or has been extrapolated from maps incorporated in the ASCE 7 standard. While ASCE has made every effort to use data obtained from reliable sources or methodologies, ASCE does not make any representations or warranties as to the accuracy, completeness, reliability, currency, or quality of any data provided herein. Any third-party links provided by this Tool should not be construed as an endorsement, affiliation, relationship, or sponsorship of such third-party content by or from ASCE.

ASCE does not intend, nor should anyone interpret, the results provided by this Tool to replace the sound judgment of a competent professional, having knowledge and experience in the appropriate field(s) of practice, nor to substitute for the standard of care required of such professionals in interpreting and applying the contents of this Tool or the ASCE 7 standard.

In using this Tool, you expressly assume all risks associated with your use. Under no circumstances shall ASCE or its officers, directors, employees, members, affiliates, or agents be liable to you or any other person for any direct, indirect, special, incidental, or consequential damages arising from or related to your use of, or reliance on, the Tool or any information obtained therein. To the fullest extent permitted by law, you agree to release and hold harmless ASCE from any and all liability of any nature arising out of or resulting from any use of data provided by the ASCE 7 Hazard Tool.